

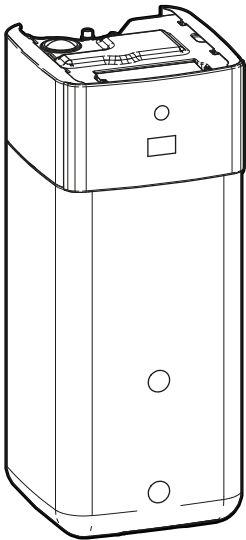

# Installation manual



## Daikin Altherma 4 H ECH<sub>2</sub>O



EPSX07P30A▲▼  
EPSX07P50A▲▼  
EPSXB07P30A▲▼  
EPSXB07P50A▲▼

▲ = 1, 2, 3, ..., 9, A, B, C, ..., Z  
▼ = , , 1, 2, 3, ..., 9

## Table of contents

<b>1</b>	<b>About the documentation</b>	<b>2</b>	[10.5] System 2/4 .....	29
1.1	About this document.....	2	[10.6] System 3/4 .....	29
<b>2</b>	<b>Specific installer safety instructions</b>	<b>3</b>	[10.7] System 4/4 .....	30
<b>3</b>	<b>About the box</b>	<b>4</b>	[10.8] Backup heater .....	30
3.1	Indoor unit.....	4	[10.9] Main zone 1/4 .....	30
3.1.1	To remove the accessories from the indoor unit.....	4	[10.10] Main zone 2/4 .....	31
3.1.2	To handle the indoor unit .....	4	[10.11] Main zone 3/4 (Heating WD curve).....	31
<b>4</b>	<b>Unit installation</b>	<b>5</b>	[10.12] Main zone 4/4 (Cooling WD curve).....	31
4.1	Preparing the installation site .....	5	[10.13] Additional zone 1/4 .....	31
4.1.1	Installation site requirements of the indoor unit .....	5	[10.14] Additional zone 2/4 .....	31
4.2	Opening and closing the unit.....	5	[10.15] Additional zone 3/4 (Heating WD curve) .....	31
4.2.1	To open the indoor unit.....	5	[10.16] Additional zone 4/4 (Cooling WD curve) .....	32
4.2.2	To close the indoor unit.....	7	[10.17] Configuration wizard – DHW 1/2 .....	32
4.3	Installing the indoor unit.....	7	[10.18] Configuration wizard – DHW 2/2 .....	32
4.3.1	To install the indoor unit.....	7	[10.19] Configuration wizard .....	32
4.3.2	To connect the drain hose to the drain .....	7	7.2 Weather-dependent curve.....	32
<b>5</b>	<b>Piping installation</b>	<b>8</b>	7.2.1 What is a weather-dependent curve? .....	32
5.1	Preparing water piping.....	8	7.2.2 Using weather-dependent curves .....	33
5.1.1	To check the water volume and flow rate .....	9	7.3 Menu structure: Overview installer settings.....	33
5.2	Connecting water piping .....	9	<b>8 Commissioning</b>	<b>34</b>
5.2.1	To connect the water piping.....	9	8.1 Checklist before commissioning .....	35
5.2.2	To connect the additional piping .....	10	8.2 Checklist during commissioning .....	36
5.2.3	To connect the expansion vessel.....	11	8.2.1 To unlock the outdoor unit (compressor) .....	36
5.2.4	To fill the heating system .....	11	8.2.2 To open the stop valve of the outdoor unit's refrigerant vessel .....	38
5.2.5	To protect the water circuit against freezing .....	11	8.2.3 To update the user interface software .....	38
5.2.6	To fill the heat exchanger inside the storage tank .....	12	8.2.4 To check the minimum flow rate .....	38
5.2.7	To fill the storage tank.....	12	8.2.5 To perform an air purge .....	39
5.2.8	To insulate the water piping .....	12	8.2.6 To perform an operation test run .....	39
<b>6</b>	<b>Electrical installation</b>	<b>12</b>	8.2.7 To perform an actuator test run .....	40
6.1	About electrical compliance.....	13	8.2.8 To perform an underfloor heating screed dryout.....	41
6.2	Guidelines when connecting the electrical wiring .....	13	<b>9 Hand-over to the user</b>	<b>42</b>
6.3	Field IO connections.....	13	<b>10 Technical data</b>	<b>43</b>
6.4	Connections to the indoor unit.....	14	10.1 Piping diagram: Indoor unit.....	43
6.4.1	To connect the electrical wiring to the indoor unit.....	16	10.2 Wiring diagram: Indoor unit .....	44
6.4.2	To connect the main power supply .....	18	<b>1 About the documentation</b>	
6.4.3	To connect the backup heater power supply .....	19	<b>1.1 About this document</b>	
6.4.4	To connect the normally closed shut-off valve (inlet leak stop) .....	20	<b>Target audience</b>	
6.4.5	To connect the shut-off valve.....	20	Authorised installers	
6.4.6	To connect the pumps (DHW pump and/or external pumps).....	21	<b>Documentation set</b>	
6.4.7	To connect the domestic hot water ON signal .....	22	This document is part of a documentation set. The complete set consists of:	
6.4.8	To connect the alarm output .....	22	<ul style="list-style-type: none"> <li>▪ <b>General safety precautions:</b> <ul style="list-style-type: none"> <li>▪ Safety instructions that you must read before installing</li> <li>▪ Format: Paper (in the box of the indoor unit)</li> </ul> </li> <li>▪ <b>Operation manual:</b> <ul style="list-style-type: none"> <li>▪ Quick guide for basic usage</li> <li>▪ Format: Paper (in the box of the indoor unit)</li> </ul> </li> <li>▪ <b>User reference guide:</b> <ul style="list-style-type: none"> <li>▪ Detailed step-by-step instructions and background information for basic and advanced usage</li> <li>▪ Format: Digital files on <a href="https://www.daikin.eu">https://www.daikin.eu</a>. Use the search function  to find your model.</li> </ul> </li> <li>▪ <b>Installation manual – Outdoor unit:</b> <ul style="list-style-type: none"> <li>▪ Installation instructions</li> <li>▪ Format: Paper (in the box of the outdoor unit)</li> </ul> </li> <li>▪ <b>Installation manual – Indoor unit:</b> <ul style="list-style-type: none"> <li>▪ Installation instructions</li> <li>▪ Format: Paper (in the box of the indoor unit)</li> </ul> </li> </ul>	
6.4.9	To connect the space cooling/heating ON/OFF output.....	22		
6.4.10	To connect the changeover to external heat source... ..	22		
6.4.11	To connect the bivalent bypass valve .....	23		
6.4.12	To connect the electricity meters .....	23		
6.4.13	To connect the safety thermostat.....	23		
6.4.14	Smart Grid.....	24		
6.4.15	To connect the WLAN cartridge (delivered as accessory).....	26		
6.4.16	To connect the Ethernet (Modbus) cable.....	26		
6.4.17	To connect the solar input.....	27		
6.4.18	To connect the gas meter .....	27		
<b>7</b>	<b>Configuration</b>	<b>27</b>		
7.1	Configuration wizard.....	28		
	[10.1] Location and language .....	28		
	[10.2] Timezone .....	28		
	[10.3] Time/date .....	28		
	[10.4] System 1/4 .....	29		

## 2 Specific installer safety instructions

- **Installer reference guide:**
  - Preparation of the installation, good practices, reference data, ...
  - Format: Digital files on <https://www.daikin.eu>. Use the search function 🔍 to find your model.
- **Configuration reference guide:**
  - Configuration of the system.
  - Format: Digital files on <https://www.daikin.eu>. Use the search function 🔍 to find your model.
- **Addendum book for optional equipment:**
  - Additional info about how to install optional equipment
  - Format: Paper (in the box of the indoor unit) + Digital files on <https://www.daikin.eu>. Use the search function 🔍 to find your model.

The latest revision of the supplied documentation is published on the regional Daikin website and is available via your dealer.

The original instructions are written in English. All other languages are translations of the original instructions.

### Technical engineering data

- A **subset** of the latest technical data is available on the regional Daikin website (publicly accessible).
- The **full set** of the latest technical data is available on the Daikin Business Portal (authentication required).

### Online tools

In addition to the documentation set, some online tools are available for installers:

- **Daikin Technical Data Hub**
  - Central hub for technical specifications of the unit, useful tools, digital resources, and more.
  - Publicly accessible via <https://daikintechnicaldatahub.eu>.
- **Heating Solutions Navigator**
  - Digital toolbox that offers a variety of tools to facilitate the installation and configuration of heating systems.
  - To access the Heating Solutions Navigator, registration to the Stand By Me platform is required. For more information, see <https://professional.standbyme.daikin.eu>.
- **Daikin e-Care**
  - Mobile app for installers and service technicians that allows you to register, configure and troubleshoot heating systems.
  - Use the QR codes below to download the mobile app for iOS and Android devices. Registration to the Stand By Me platform is required to access the app.

App Store



Google Play



## 2 Specific installer safety instructions

Always observe the following safety instructions and regulations.

**Installation site** (see ["4.1 Preparing the installation site"](#) ▶ 5)



### WARNING

Follow the service space dimensions in this manual to install the unit correctly. See ["4.1.1 Installation site requirements of the indoor unit"](#) ▶ 5).



### CAUTION

Install the indoor unit at a minimum distance of 1 m from other heat sources (>80°C) (e.g. electrical heater, oil heater, chimney) and combustible materials. Otherwise the unit may be damaged or in extreme cases catch fire.

**Opening and closing the unit** (see ["4.2 Opening and closing the unit"](#) ▶ 5)



### DANGER: RISK OF ELECTROCUTION



### DANGER: RISK OF BURNING/SCALDING

**Installing the indoor unit** (see ["4.3 Installing the indoor unit"](#) ▶ 7)



### WARNING

The indoor unit installation **MUST** be in accordance with the instructions from this manual. See ["4.3 Installing the indoor unit"](#) ▶ 7).

**Piping installation** (see ["5 Piping installation"](#) ▶ 8)



### WARNING

Field piping **MUST** be in accordance with the instructions from this manual. See ["5 Piping installation"](#) ▶ 8).



### DANGER: RISK OF ELECTROCUTION

During the filling process, water can escape from any leaking point and can cause an electrical shock if it comes into contact with live parts.

- Before the filling process, de-energise the unit.
- After the first filling and before switching on the unit with the mains switch, check whether all electric parts and connection points are dry.



### WARNING

Adding anti-freeze solutions (e.g. glycol) to the water is **NOT** allowed.

**Electrical installation** (see ["6 Electrical installation"](#) ▶ 12)



### DANGER: RISK OF ELECTROCUTION



### WARNING

Electrical wiring **MUST** be in accordance with the instructions from:

- This manual. See ["6 Electrical installation"](#) ▶ 12].
- The wiring diagram, which is delivered with the unit, located on the inside of the indoor unit switch box cover. For a translation of its legend, see ["10.2 Wiring diagram: Indoor unit"](#) ▶ 44].



### WARNING

- All wiring **MUST** be performed by an authorised electrician and **MUST** comply with the applicable national wiring regulation.
- Make electrical connections to the fixed wiring.
- All components procured on-site and all electrical construction **MUST** comply with the applicable legislation.



### WARNING

**ALWAYS** use multicore cable for power supply cables.



### WARNING

The backup heater **MUST** have a dedicated power supply and **MUST** be protected by the safety devices required by the applicable legislation.

## 3 About the box

### WARNING

If the supply cord is damaged, it **MUST** be replaced by the manufacturer, its service agent or similarly qualified persons in order to avoid a hazard.

### CAUTION

Do **NOT** push or place redundant cable length into the unit.

### CAUTION

To guarantee the unit is completely earthed, **ALWAYS** connect the backup heater power supply and the earth cable.

### INFORMATION

For details on the fuse ratings, the fuse types and the circuit breaker ratings, see "6 Electrical installation" [▶ 12].

### Commissioning (see "8 Commissioning" [▶ 34])

### WARNING

Commissioning **MUST** be in accordance with the instructions from this manual. See "8 Commissioning" [▶ 34].

### WARNING

After commissioning, do **NOT** turn OFF the circuit breakers (c) to the units so that the protection remains activated. In case of indoor unit supplied separately (a), there are two circuit breaker. In case of indoor unit supplied from the outdoor unit (b), there is one circuit breaker.

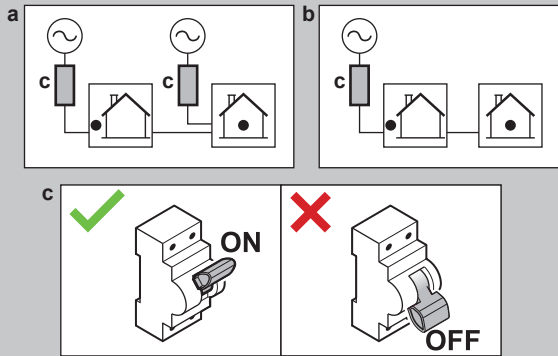

## 3 About the box

Keep the following in mind:

- At delivery, the unit **MUST** be checked for damage and completeness. Any damage or missing parts **MUST** be reported immediately to the claims agent of the carrier.
- Bring the packed unit as close as possible to its final installation position to prevent damage during transport.
- Prepare in advance the path along which you want to bring the unit to its final installation position.

### 3.1 Indoor unit

### INFORMATION

The indoor unit is delivered with closed locking parts. Open the locking parts before you start with the installation of the indoor unit. The rear locking parts are maybe no longer accessible when the indoor unit is at the final installation location. (see "4.2.1 To open the indoor unit" [▶ 5]).

### 3.1.1 To remove the accessories from the indoor unit

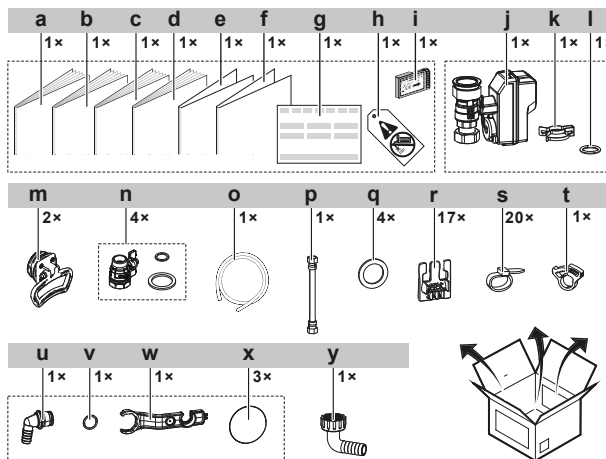
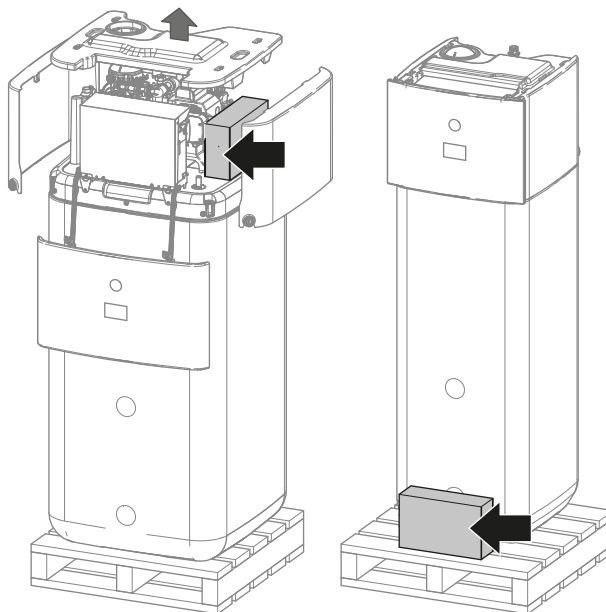

- a Indoor unit installation manual
- b Operation manual
- c General safety precautions
- d Addendum book for optional equipment
- e Addendum – Updating the BRC1HH\* firmware
- f Addendum Triman
- g Declaration of conformity
- h No glycol tag (to attach to the field piping near the filling point)
- i WLAN cartridge
- j Normally closed shut-off valve (inlet leak stop)
- k Quick clip
- l O-ring
- m Handles (only required for transport)
- n Shut-off valve with flat gaskets
- o Drain pan hose
- p Flexible hose (for expansion vessel)
- q Flat gaskets for DHW
- r Cable fixation for strain relief
- s Cable tie
- t Drain pan hose clamp
- u Spillover connector
- v O-ring
- w Assembly wrench
- x Thread cover
- y Drain hose connector magnetic filter

### 3.1.2 To handle the indoor unit

Use the handles at the back and at the front to carry the unit.

## NOTICE

The indoor unit is top-heavy as long as the storage tank is empty. Secure the unit accordingly and only transport by using the handles.

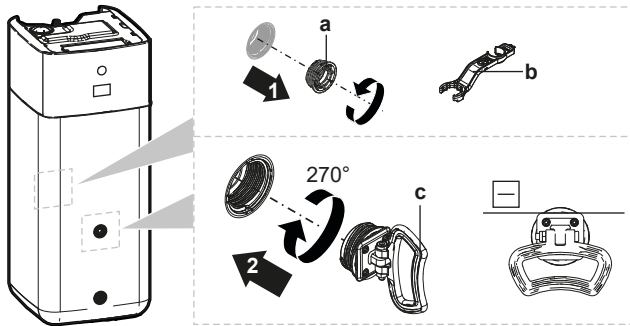

- a Screw plug
- b Assembly wrench
- c Handle

- 1 Open the screw plugs on the front and back of the tank.
- 2 Attach the handles horizontally and turn by 360°.
- 3 Use the handles to carry the unit.
- 4 After carrying the unit remove the handles, add the screw plugs again and insert the thread covers on the plugs.

## 4 Unit installation

### 4.1 Preparing the installation site

#### 4.1.1 Installation site requirements of the indoor unit

- The indoor unit is designed for indoor installation only and for the following ambient temperatures:
  - Space heating operation: 5~30°C
  - Space cooling operation: 5~35°C
  - Domestic hot water production: 5~35°C.
- Mind the measurement guidelines:

Maximum height difference between indoor unit and outdoor unit	10 m
Maximum water piping length (single run) between outdoor unit and indoor unit in case of...	
EPSKS04+06	
1" field piping	20 m <sup>(a)</sup>
EPSKS07	
1" field piping	7 m <sup>(a)</sup>
1 1/4" field piping	20 m <sup>(a)</sup>

<sup>(a)</sup> The precise water piping length can be determined using the Hydronic Piping Calculation tool. The Hydronic Piping Calculation tool is part of the Heating Solutions Navigator which can be reached via <https://professional.standby.me.daikin.eu>. Contact your dealer if you have no access to the Heating Solutions Navigator.

- Mind the following spacing installation guidelines:

## CAUTION

Install the indoor unit at a minimum distance of 1 m from other heat sources (>80°C) (e.g. electrical heater, oil heater, chimney) and combustible materials. Otherwise the unit may be damaged or in extreme cases catch fire.

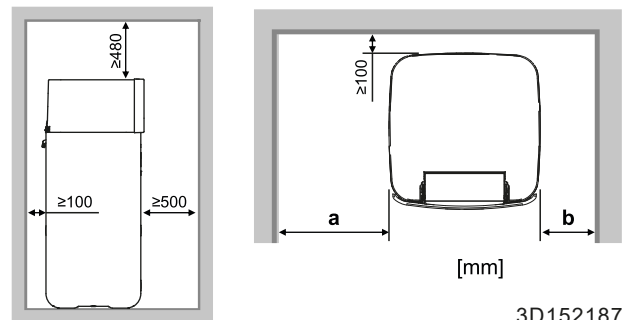

3D152187

a	≥400 mm
b	≥100 mm
a+b	≥500 mm

## INFORMATION

Serviceability may be impacted, if the indicated clearances cannot be maintained.

## INFORMATION

If you have limited installation space, do the following before installing the unit in its final position: "4.3.2 To connect the drain hose to the drain" [ 7].

## 4.2 Opening and closing the unit

### 4.2.1 To open the indoor unit

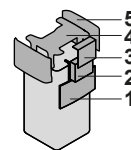

- 1 User interface panel
- 2 Switch box
- 3 Switch box cover
- 4 Top cover
- 5 Side panel

#### Lower the user interface panel

- 1 Open the hinges at the top the user interface panel.

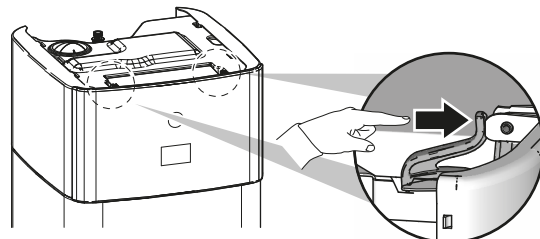

- 2 Lower the user interface panel downwards with both hands.

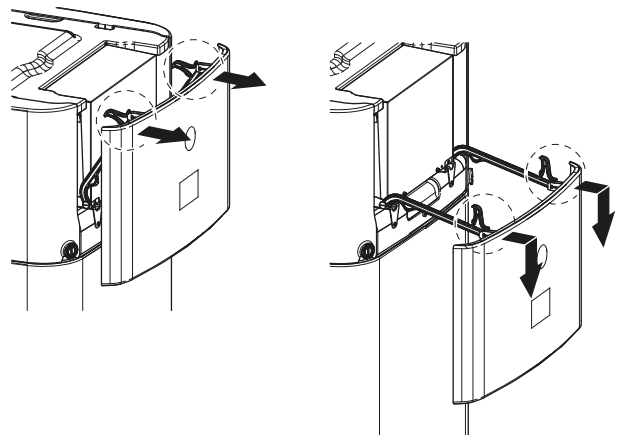

#### Open the switchbox cover

- 1 Loosen the screws and open the switch box cover.

## 4 Unit installation

### NOTICE

Do NOT damage or remove the foam sealing of the switch box.

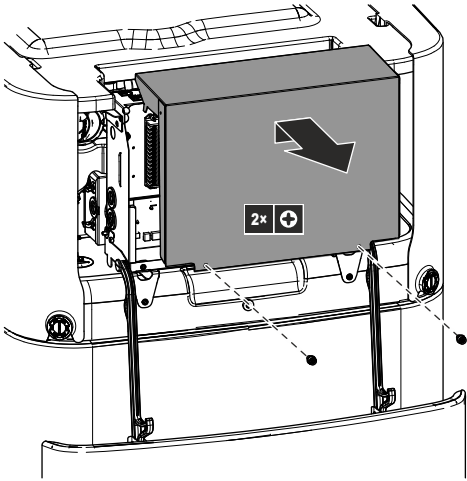

### To lower the switch box and open the switch box cover

During the installation, you will need access to the inside of the indoor unit. To have easier front access, lower the switch box of the unit as follows:

**Prerequisite:** The user interface panel has been lowered.

- 1 Loosen the screws of the switch box.
- 2 Lift up the switch box.

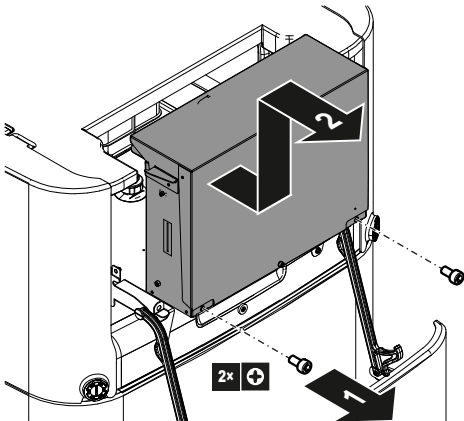

- 3 Lower the switch box.
- 4 Loosen the screws and open the switch box cover.

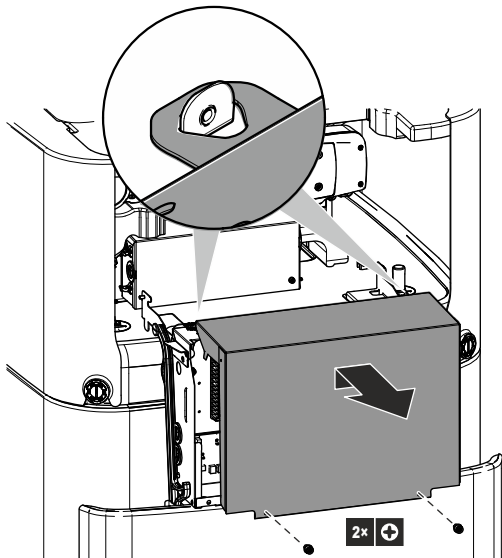

### Remove the top cover

During the installation, you will need access to the inside of the indoor unit. To have easier top access, remove the top cover of the unit. This is necessary in the following cases:

- Installation DB-kit
- Installation expansion vessel
- Fill the heating system

**Prerequisite:** The user interface panel has been lowered.

- 1 Open the locking parts of the side panels with a screw driver.

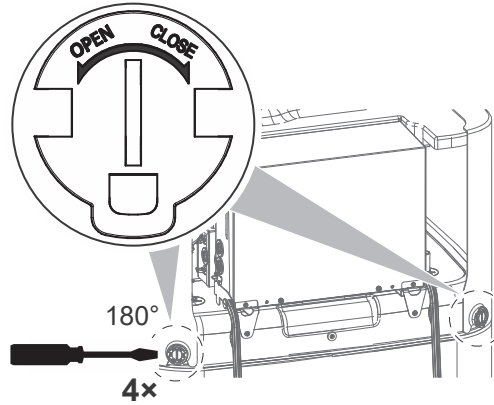

- 2 Lift up the side panels.

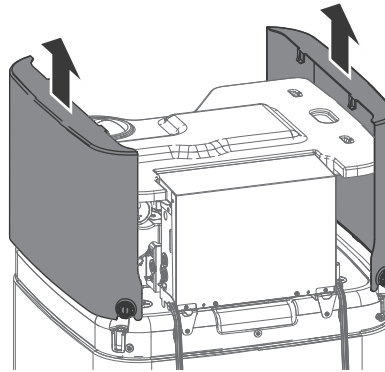

- 3 Remove the top cover

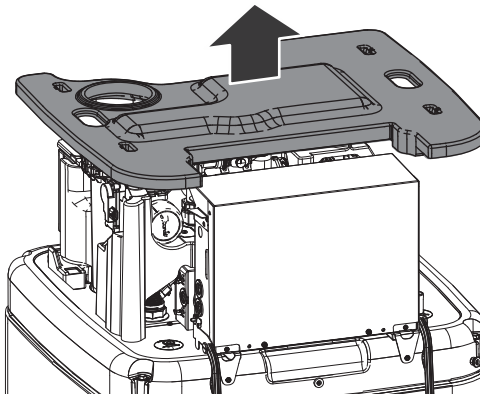

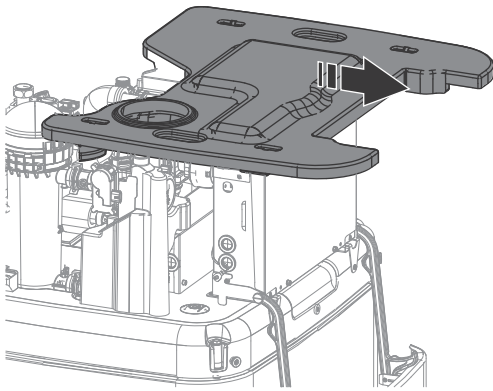

## 4.2.2 To close the indoor unit

- 1 Place the top cover on the top of the unit.
- 2 Hang the side panels into the top cover.
- 3 Check that the hooks of the side panel slide correctly into the cut-outs in the top cover.
- 4 Check that the locking parts of the side panels slide onto the plugs of the tank.
- 5 Close the locking parts of the side panels.
- 6 Close the cover of the switch box.
- 7 Put the switch box back into place.
- 8 Close the user interface panel.



### NOTICE

When closing the indoor unit, make sure that the tightening torque does NOT exceed 2.9 N•m.



### NOTICE

Close at least one locking part per side panel. If you cannot reach the locking parts on the back of the indoor unit, it is sufficient to close only the locking parts on the front.

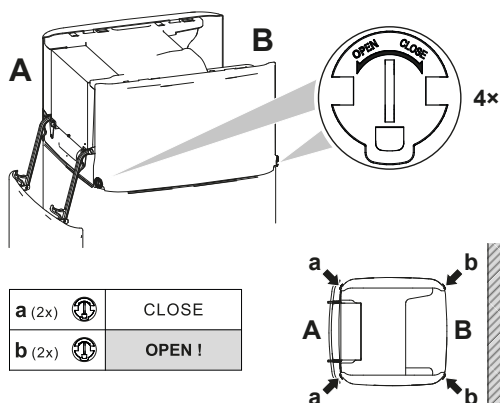

### NOTICE

**Level.** Make sure the unit is level.

## 4.3.2 To connect the drain hose to the drain

Spillover water from the water storage tank as well as water collecting in the drain pan must be drained. You must connect the drain hoses to an appropriate drain according to the applicable legislation.

- 1 Open the screw plug.

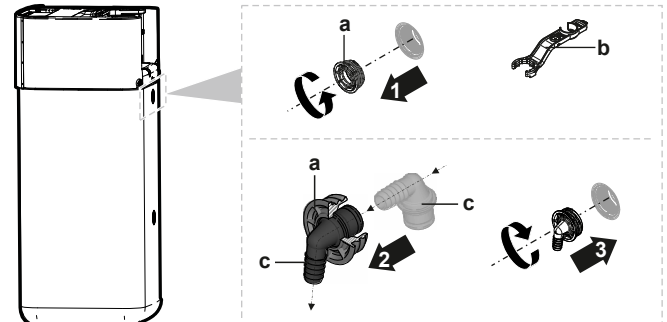

- a Screw plug
- b Assembly wrench
- c Spillover connector

- 2 Insert the spillover connector into the screw plug.
- 3 Mount the spillover connector.
- 4 Attach a drain hose to the spillover connector.
- 5 Connect the drain hose to an appropriate drain. Ensure the water can flow through the drain hose. Ensure that the water level cannot mount above the overspill.
- 6 Connect the drain pan hose to the drain pan connection and connect to an appropriate drain.
- 7 Connect the drain hose to the pressure relief valve connection and connect to an appropriate drain in accordance with the applicable legislation. Ensure that any steam or water that may escape is drained in a frost-protected, safe and observable manner.

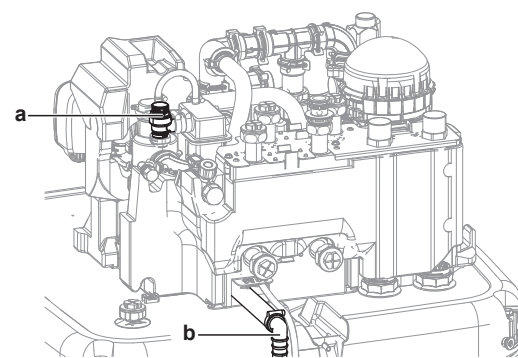

- a Pressure relief valve
- b Pressure relief valve connection

## 4.3 Installing the indoor unit

### 4.3.1 To install the indoor unit

- 1 Lift the indoor unit from the pallet and place it on the floor. Also see "3.1.2 To handle the indoor unit" [▶ 4].
- 2 Connect the drain hose to the drain. See "4.3.2 To connect the drain hose to the drain" [▶ 7].
- 3 Slide the indoor unit into position.

## 5 Piping installation

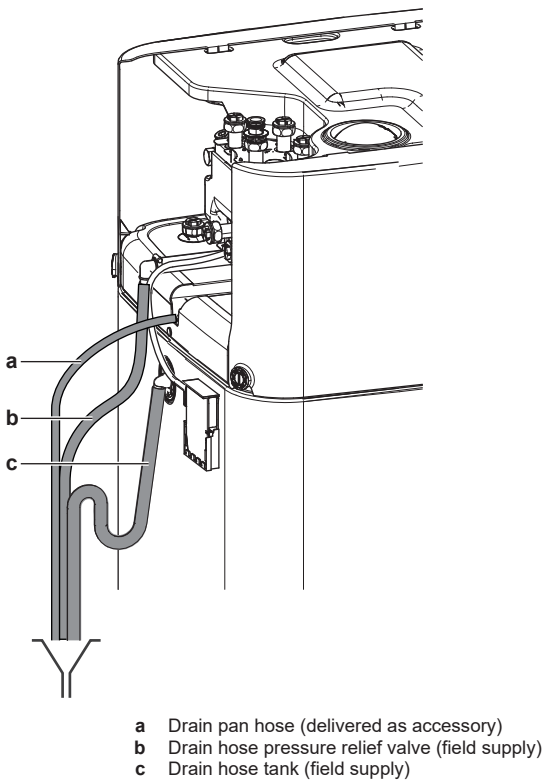

## 5 Piping installation

### 5.1 Preparing water piping

#### NOTICE

In case of plastic pipes, make sure they are fully oxygen diffusion tight according to DIN 4726. The diffusion of oxygen into the piping can lead to excessive corrosion.

#### NOTICE

**Water circuit requirements.** Make sure to comply with the water pressure and water temperature requirements below. For additional water circuit requirements, see the installer reference guide.

- **Water pressure – Domestic hot water.** The maximum water pressure is 10 bar (=1.0 MPa), and must be in accordance with the applicable legislation. Provide adequate safeguards in the water circuit to ensure that the maximum pressure is NOT exceeded (see "5.2.1 To connect the water piping" [p 9]). The minimum water pressure to operate is 1 bar (=0.1 MPa).
- **Water pressure – Space heating/cooling circuit.** The maximum water pressure is 3 bar (=0.3 MPa). Provide adequate safeguards in the water circuit to ensure that the maximum pressure is NOT exceeded. The minimum water pressure to operate is 1 bar (=0.1 MPa).
- **Water pressure – Storage tank.** The water inside the storage tank is not pressurized. Therefore, a visual check via level indicator on the storage tank must be carried out annually.

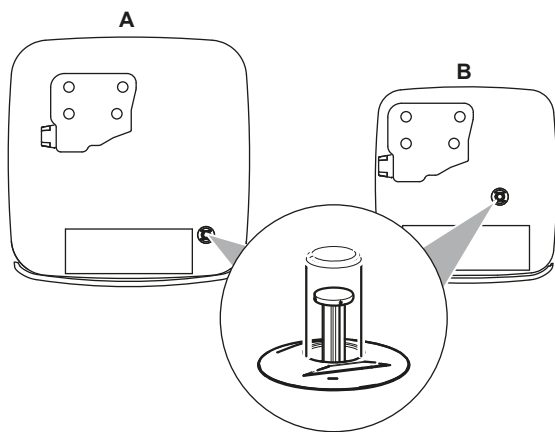

- **Water temperature.** All installed piping and piping accessories (valve, connections,...) MUST withstand the following temperatures:

#### INFORMATION

The following figure is an example and may NOT completely match your system layout.

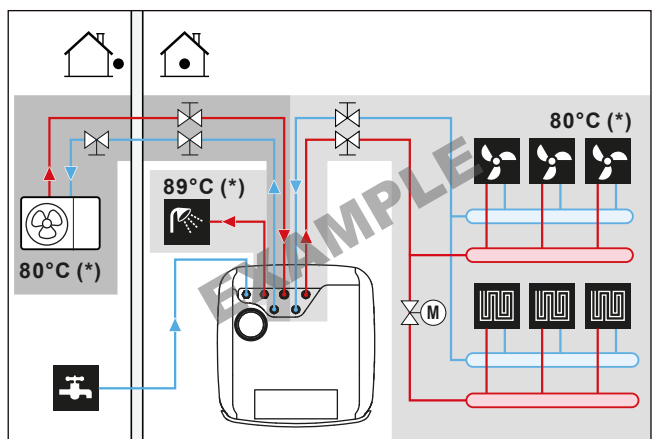

(\*) Maximum temperature for piping and accessories

#### INFORMATION

The maximum leaving water temperature is decided based on setting [3.12] Overheating setpoint. This limit defines the maximum leaving water **in the system**. Depending on the value of this setting, the maximum LWT setpoint will also be reduced by 5°C to allow stable control towards the setpoint.

The maximum leaving water temperature **in the main zone** is decided based on setting [1.19] Overheating water circuit, only in case [3.13.5] Bizon kit installed is enabled. This limit defines the maximum leaving water **in the main zone**. Depending on the value of this setting, the maximum LWT setpoint will also be reduced by 5°C to allow stable control towards the setpoint.

- **Storage tank – Water quality.** Minimum requirements regarding the quality of water used to fill the storage tank:
  - Water hardness (calcium and magnesium, calculated as calcium carbonate): ≤3 mmol/l
  - Conductivity: ≤1500 (ideal: ≤100) μS/cm
  - Chloride: ≤250 mg/l
  - Sulphate: ≤250 mg/l
  - pH value: 6.5~8.5

For properties deviating from the minimum requirements, suitable conditioning measures have to be taken.

## 5.1.1 To check the water volume and flow rate

To make sure that the unit operates properly:

- You **MUST** check the minimum water volume and the minimum flow rate.

### Minimum water volume

The installation needs to be made in such a way that a minimum water volume (see table below) is always available in the space heating/cooling loop of the unit, even when the available volume towards the unit is reduced because of closure of valves (heat emitters, thermostatic valves, etc.) in the space heating/cooling circuit. The internal water volume of the outdoor unit is **NOT** considered for this minimum water volume.

If...	Then the minimum water volume is...
Cooling operation	For EPSX(B)07: 13 l
Heating/defrost operation	For EPSX(B)07: 0 l

### Minimum flow rate

Check that the minimum flow rate in the installation is guaranteed in all conditions.

If operation is...	Then the minimum flow rate is...
Cooling / heating start-up / defrost / backup heater operation	Required: For EPSX(B)07: 20 l/min



### NOTICE

When circulation in each or certain space heating loops is controlled by remotely controlled valves, it is important that the minimum flow rate is guaranteed, even if all valves are closed. In case the minimum flow rate cannot be reached, a flow error 7H will be generated.

See the installer reference guide for more information.

See the recommended procedure as described in "8.2 Checklist during commissioning" [p 36].

## 5.2 Connecting water piping

### 5.2.1 To connect the water piping



### NOTICE

Do **NOT** use excessive force when connecting the field piping and make sure the piping is aligned properly. Deformed pipes can cause the unit to malfunction.

Delivered as accessory:

1 normally closed shut-off valve (inlet leak stop) (O-ring + quick clip)	To prevent refrigerant from entering the indoor unit in case of a refrigerant leak in the outdoor unit.
4 shut-off valves (+ flat gaskets)	To facilitate service and maintenance.

- Install the normally closed shut-off valve (inlet leak stop) with the O-ring and the quick clip. (Connect the wiring see "6.4.4 To connect the normally closed shut-off valve (inlet leak stop)" [p 20]).
- Install the shut-off valves with the flat gaskets:

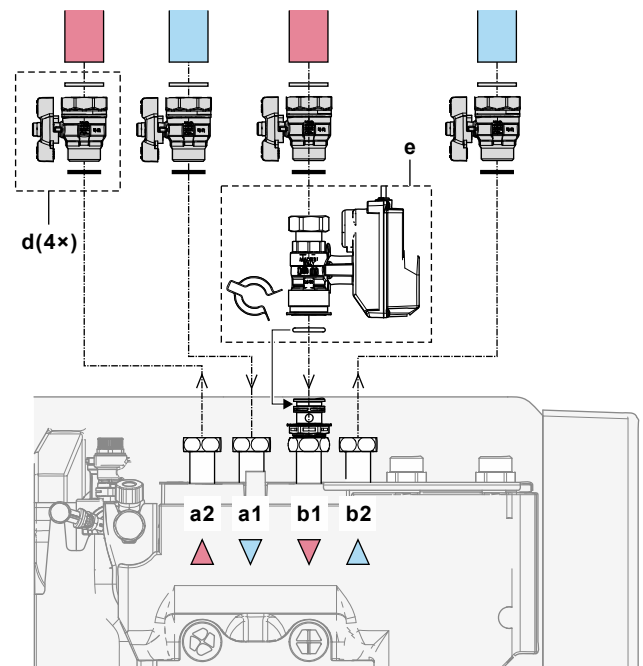

- Install the domestic water piping using the special flat gaskets for DWH:

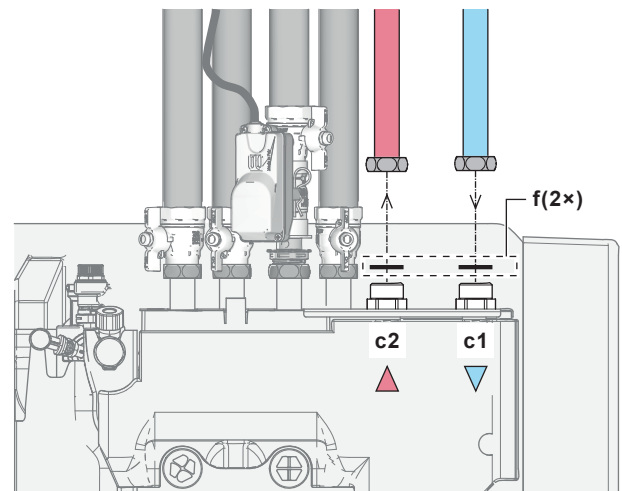

- Install the piping as follows:

## 5 Piping installation

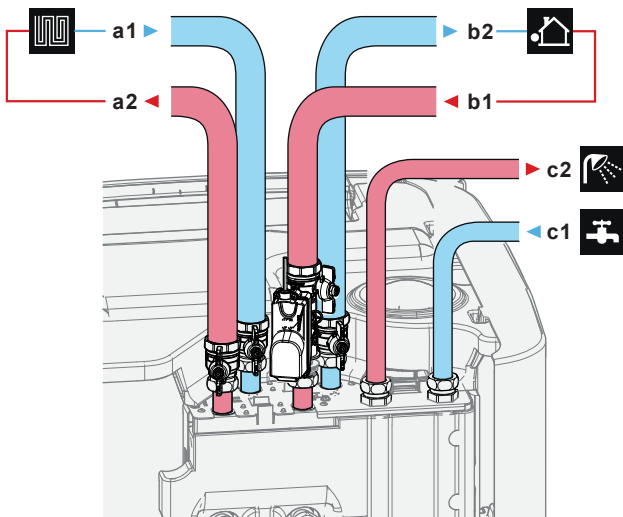

- a1 Space heating/cooling – Water IN (female, 1")
- a2 Space heating/cooling – Water OUT (female, 1")
- b1 Water IN from outdoor unit (female, 1")
- b2 Water OUT to outdoor unit (female, 1")
- c1 DHW – Cold water IN (male, 1")
- c2 DHW – Hot water OUT (male, 1")

5 Install the following components (field supply) on the cold water inlet of the DHW tank:

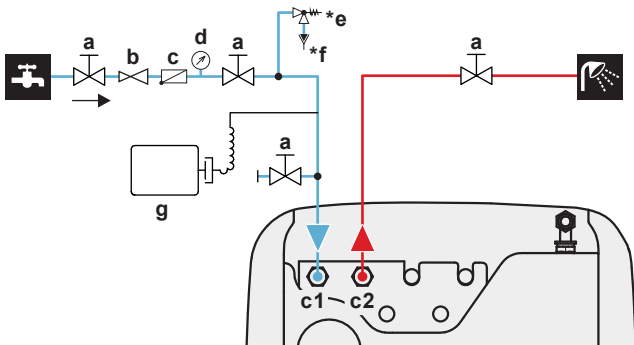

- a Shut-off valve (recommended)
- c1 DHW – Cold water IN (male, 1")
- c2 DHW – Hot water OUT (male, 1")
- b Pressure reducing valve (recommended)
- c Non-return valve (recommended)
- d Pressure gauge (recommended)
- \*e Pressure relief valve (max. 10 bar (=1.0 MPa)) (mandatory)
- \*f Tundish (mandatory)
- g Expansion vessel (recommended)

Do NOT exceed the maximum tightening torque (Thread size 1", 25-30 N•m). To avoid damage, apply the necessary countertorque with a suitable tool.

### NOTICE

Install air purge valves at all local high points.

### NOTICE

A pressure relief valve (field supply) with an opening pressure of maximum 10 bar (=1 MPa) must be installed on the domestic cold water inlet connection in accordance with the applicable legislation.

### NOTICE

- A drain device and pressure relief device must be installed on the cold water inlet connection of the storage tank.
- To avoid back siphonage, it is recommended to install a non-return valve on the water inlet of the storage tank in accordance with the applicable legislation. Make sure it is NOT between the pressure relief valve and the storage tank.
- It is recommended to install a pressure reducing valve on the cold water inlet in accordance with the applicable legislation.
- It is recommended to install an expansion vessel on the cold water inlet in accordance with the applicable legislation.
- It is recommended to install the pressure relief valve on a higher position than the top of the storage tank. Heating of the storage tank causes water to expand and without pressure relief valve the water pressure of the domestic hot water heat exchanger inside the tank can rise above design pressure. Also the field installation (piping, tapping points, etc.) connected to the tank is subjected to this high pressure. To prevent this, a pressure relief valve needs to be installed. The overpressure prevention depends on the correct operation of the field installed pressure relief valve. If this is NOT working correctly, water leakage may occur. To confirm good operation, regular maintenance is required.

### 5.2.2 To connect the additional piping

To connect the drainback piping

1 Install the piping as follows:

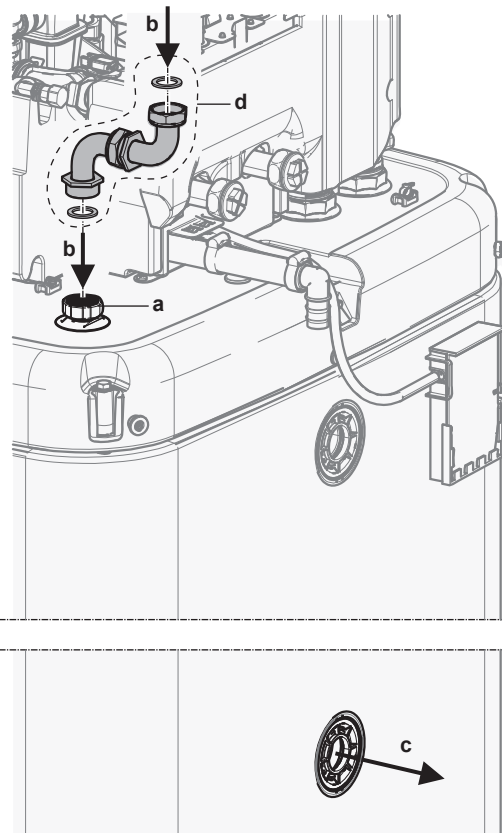

- a Drainback connection
- b Drainback – Water IN
- c Drainback – Water OUT
- d Drainback connection kit (EKECDBC03A\*)

## To connect the bivalent piping

In case of a bivalent unit with heat exchanger inside the tank.

- 2 Install the piping as follows:

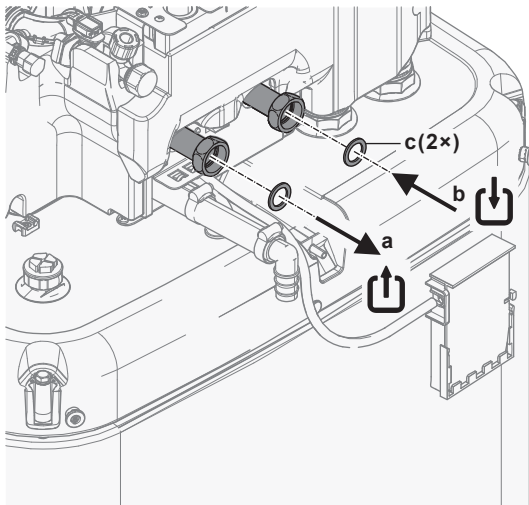

- a Bivalent – Water OUT (screw connection, 1 ")
- b Bivalent – Water IN (screw connection, 1 ")
- c Flat gaskets for DHW (delivered as accessory)

## 5.2.3 To connect the expansion vessel

- 1 Connect a suitably dimensioned and preset expansion vessel for the heating system. There may not be any hydraulic blocking elements between the heat generator and the safety valve.
- 2 Position the pressure vessel in an easily accessible place (maintenance, parts replacement).

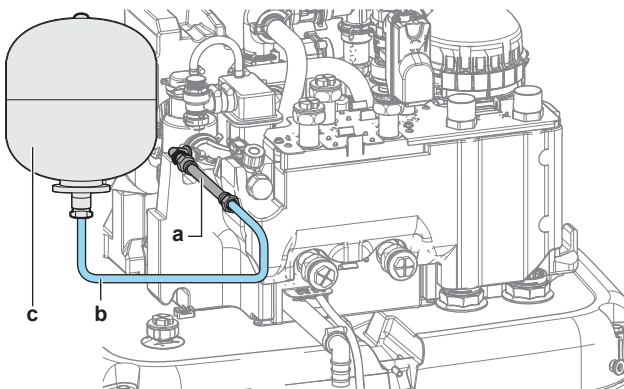

- a Flexible hose (delivered as accessory)
- b Hose (field supply)
- c Expansion vessel (field supply)

## 5.2.4 To fill the heating system



### DANGER: RISK OF ELECTROCUTION

During the filling process, water can escape from any leaking point and can cause an electrical shock if it comes into contact with live parts.

- Before the filling process, de-energise the unit.
- After the first filling and before switching on the unit with the mains switch, check whether all electric parts and connection points are dry.



### NOTICE

When filling the heating system check the water pressure at the domestic water supply. If the pressure in the domestic water supply is higher than 3 bar (= 0.3 MPa), install a pressure reducing valve and limit the water pressure to a maximum of 3 bar (= 0.3 MPa).

- 1 Connect a hose with a non-return valve (1/2") and an external manometer (field supply) to a water tap and the fill and drain valve. Secure the hose against slipping off.

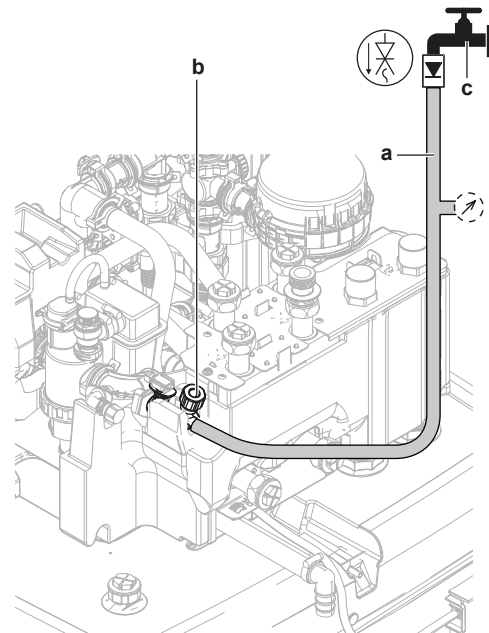

- a Hose with a non-return valve (1/2") and an external manometer (field supply)
- b Fill and drain valve
- c Water tap

- 2 Open the water tap.
- 3 Open fill and drain valve and monitor the manometer.
- 4 Fill the system with water until the external manometer shows that the system target pressure is reached (system height +2 m; 1 m water column = 0.1 bar). Make sure that the pressure relief valve does not open.
- 5 Close the water tap. Keep the fill and drain valve open in case it is necessary to repeat the filling procedure after air purging of the system. See "8.2.5 To perform an air purge" [ 39].
- 6 Close the fill and drain valve and remove the hose with non-return valve only after air purging is performed and the system is completely filled.

## 5.2.5 To protect the water circuit against freezing

### About freeze protection

Frost can damage the system. To prevent the hydraulic components from freezing, the unit is equipped with the following:

- The software is equipped with special frost protection functions such as water pipe freeze prevention that include the activation of a pump in case of low temperatures. However, in case of a power failure, these functions cannot guarantee protection.
- The outdoor unit is equipped with two factory mounted freeze protection valves. Freeze protection valves drain the water from the outdoor unit before it can freeze and damage the unit. This is to prevent R290 leaks in the outdoor unit. **Note:** The factory mounted freeze protection valves are designed to protect the outdoor unit, not the field piping.

## 6 Electrical installation

To ensure protection of field piping, install **additional freeze protection valves** at all lowest points of the field piping. Insulate these field installed freeze protection valves in a similar way as the water piping, but do NOT insulate the inlet and outlet (release) of these valves.

Optionally, you can install **normally closed valves** (located indoors near the piping entry/exit points). These valves can prevent that all water from the indoor piping is drained when the freeze protection valves open. **Note:** The normally closed shut-off valve that is delivered as accessory with the indoor unit, which is mandatory to install on the indoor unit for safety reasons (inlet leak stop), does NOT prevent drainage of the indoor piping when the freeze protection valves open. For this, you need additional normally closed valves (optional).

For more information, see the installer reference guide.

### NOTICE

When freeze protection valves are installed, set the minimum cooling setpoint (default=7°C) at least 2°C higher than the maximum opening temperature of the freeze protection valves (the opening temperature of the factory-mounted freeze protection valves is 3°C ±1).

If you set the minimum cooling setpoint lower than the safe value (i.e. maximum opening temperature of freeze protection valves + 2°C), you risk that the freeze protection valves open when cooling to the minimum setpoint.

### INFORMATION

The minimum leaving water temperature is decided based on setting [3.11] Undercooling setpoint. This limit defines the minimum leaving water in the system. Depending on the value of this setting, the minimum LWT setpoint will also be increased by 4°C to allow stable control towards the setpoint.

The minimum leaving water temperature in the main zone is decided based on setting [1.20] Undercooling water circuit, only in case [3.13.5] Bizone kit installed is enabled. This limit defines the minimum leaving water in the main zone. Depending on the value of this setting, the minimum LWT setpoint will also be increased by 4°C to allow stable control towards the setpoint.

### WARNING

Adding anti-freeze solutions (e.g. glycol) to the water is NOT allowed.

### 5.2.6 To fill the heat exchanger inside the storage tank

Following heat exchanger has to be filled with water before the storage tank can be filled:

- The domestic hot water heat exchanger

### NOTICE

To fill the domestic hot water heat exchanger, use a field supply filling kit. Make sure you comply with the applicable legislation.

- 1 Open the shut-off valve for the cold water supply.
  - 2 Open all hot water taps in the system to make sure that the tapped water flow is as high as possible.
  - 3 Keep the hot water taps open and the cold water supply running until no more air is vented from the taps.
  - 4 Check for water leaks.
- The bivalent heat exchanger (only for some models)

- 5 Fill the bivalent heat exchanger with water by connecting the bivalent heating circuit. If the bivalent heating circuit will be installed on a later stage, fill the bivalent heat exchanger with a filling hose until water comes out of both connections.
- 6 Do air purge on the bivalent heating circuit.
- 7 Check for water leaks.

### 5.2.7 To fill the storage tank

#### NOTICE

Before the storage tank can be filled, the heat exchangers inside the storage tank have to be filled, see previous chapters.

Fill the storage tank with a water pressure <6 bar and a flow speed <15 l/min.

#### Without installed drainback solar kit (option)

- 1 Connect a hose with non-return valve (1/2") to the drainback connection.
- 2 Fill the storage tank until water spills from the spillover connection.
- 3 Remove the hose.

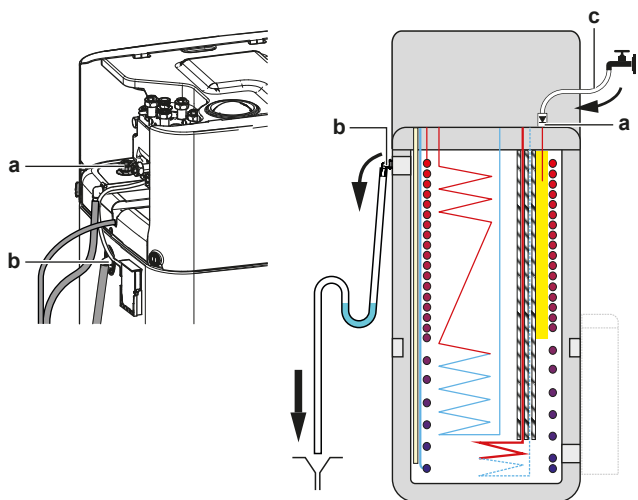

- a Drainback connection
- b Spillover connection
- c Hose with non-return valve (1/2")

#### With installed drainback solar kit (option)

- 1 Combine the fill and drain kit (option) with the drainback solar kit (option) to fill the storage tank.
- 2 Connect the hose with non-return valve to the fill and drain kit.

Follow the steps described in the previous chapter.

### 5.2.8 To insulate the water piping

The piping in the complete water circuit MUST be insulated to prevent condensation during cooling operation and reduction of the heating and cooling capacity.

#### Outdoor water piping insulation

See the installation manual of the outdoor unit, or the installer reference guide.

## 6 Electrical installation

### DANGER: RISK OF ELECTROCUTION



### WARNING

- All wiring **MUST** be performed by an authorised electrician and **MUST** comply with the applicable national wiring regulation.
- Make electrical connections to the fixed wiring.
- All components procured on-site and all electrical construction **MUST** comply with the applicable legislation.



### WARNING

ALWAYS use multicore cable for power supply cables.



### WARNING

If the supply cord is damaged, it **MUST** be replaced by the manufacturer, its service agent or similarly qualified persons in order to avoid a hazard.



### CAUTION

Do **NOT** push or place redundant cable length into the unit.



### NOTICE

The distance between the high voltage and low voltage cables should be at least 50 mm.



### NOTICE

It is recommended to install a residual current device (RCD) having a rated residual operating current **NOT** exceeding 30 mA.



### INFORMATION

When installing field supply or option cables, foresee sufficient cable length. This will make it possible to open the switch box and gain access to other components during service.

## 6.1 About electrical compliance

Only for the backup heater of the indoor unit

See "6.4.3 To connect the backup heater power supply" ▶ 19].

## 6.2 Guidelines when connecting the electrical wiring



### NOTICE

We recommend using solid wires. If stranded wires are used, slightly twist the strands to consolidate the end of the conductor for either direct use in the terminal clamp or insertion in a round crimp-style terminal. Details are described in "Guidelines when connecting the electrical wiring" in the installer reference guide.

### Tightening torques

Indoor unit:

Item	Tightening torque (N·m)
M3.5 (X42M, X43M, X44M, X45M)	0.88 ±10%
M4 (X40M, X41M)	1.47 ±10%
M4 (earth)	1.47 ±10%

## 6.3 Field IO connections

When connecting the electrical wiring, for certain components, you can choose which terminal pins to use. After connection, you must tell the user interface which terminal pins you used so that it matches your system layout:

- Preferably, via the breadcrumbs in [13] Field IO.

- Alternatively, via the field codes (see the field settings table in the installer reference guide).

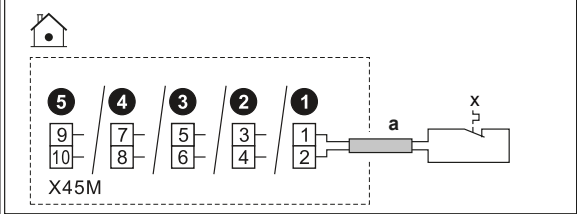
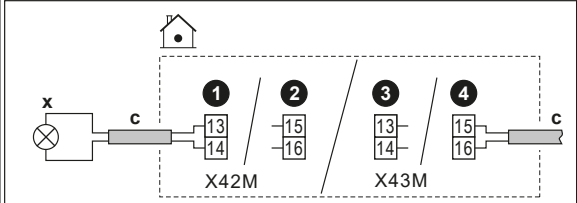
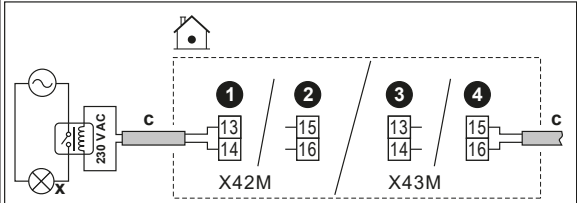
<b>1</b>	<b>Choose which terminal pins to use for which component.</b>
1a	<p>In case of Field IO inputs:</p> <p>Choose between the standard possibilities (12345) as shown in the respective topics of "6.4 Connections to the indoor unit" ▶ 14] and in the addendum book for optional equipment). For example:</p> 
1b	<p>In case of Field IO outputs:</p> <p>You have multiple options.</p>
1b.1	<p><b>Option 1 (preferred;</b> only possible if the running current and/or inrush current of the connected component does <b>NOT</b> exceed the maximum running current and/or inrush current of the terminals as listed in the respective topic):</p> <p>Choose between the standard possibilities (1234) as shown in the respective topics of "6.4 Connections to the indoor unit" ▶ 14] and in the addendum book for optional equipment). For example:</p> <ul style="list-style-type: none"> <li>Maximum running current and/or inrush current of respective terminals = 0.3 A</li> <li>Maximum running current and/or inrush current of connected component is ≤0.3 A</li> </ul> 
1b.2	<p><b>Option 2</b> (in case the running current and/or inrush current of the connected component exceeds the maximum running current and/or inrush current of the terminals as listed in the respective topic):</p> <p>Choose between the standard possibilities (1234) as shown in the respective topics of "6.4 Connections to the indoor unit" ▶ 14] and in the addendum book for optional equipment), but instead of directly connecting to the component, install a relay (field supply) with an external power supply outside of the switch box in-between. For example:</p> <ul style="list-style-type: none"> <li>Maximum running current and/or inrush current of respective terminals = 0.3 A</li> <li>Maximum running current and/or inrush current of connected component is &gt;0.3 A</li> </ul> 

## 6 Electrical installation

1b.3	<p><b>Option 3:</b></p> <p>Alternatively, instead of choosing one of the standard possibilities (1234), you can use the terminal pins of any of the other Field IO outputs. However, you must also check if the running current and/or inrush current of the connected component exceeds the maximum running current and/or inrush current of the terminals as listed in the respective topic. If exceeded, you must install a relay in-between (similar to <b>Option 2</b>).</p>								
2	<p><b>Tell the user interface which terminal pins you used for which component.</b></p>								
2.1	Go to [13] Field IO.								
2.2	<p>Select the used terminal block.</p> <p><b>Result:</b> The screen with the connections on that terminal block is shown. For example:</p> <div style="border: 1px solid black; padding: 10px; margin: 10px 0;"> <p style="text-align: center;">Field IO</p> <table border="1" style="width: 100%; border-collapse: collapse;"> <thead> <tr> <th style="width: 50%;">Terminal block X43M</th> <th style="width: 50%;">Function</th> </tr> </thead> <tbody> <tr> <td>Pin 1-3</td> <td>Shut off valve</td> </tr> <tr> <td>Pin 4-6</td> <td>External heat source</td> </tr> <tr> <td>Pin 10-11-12</td> <td>Alarm</td> </tr> </tbody> </table> <p style="margin-top: 10px;">Invert <input type="checkbox"/></p> </div>	Terminal block X43M	Function	Pin 1-3	Shut off valve	Pin 4-6	External heat source	Pin 10-11-12	Alarm
Terminal block X43M	Function								
Pin 1-3	Shut off valve								
Pin 4-6	External heat source								
Pin 10-11-12	Alarm								
2.3	On the left, select the used terminal pins.								
2.4	<p>On the right, select the connected component:</p> <ul style="list-style-type: none"> <li>▪ Field IO inputs (see table below)</li> <li>▪ Field IO outputs (see table below)</li> </ul>								
2.5	<p>Set whether the logic has to be inverted.</p> <p><b>Note:</b> not all terminals / connected options can be inverted. If the selection is possible or not is visible in [13] Field IO.</p> <table border="1" style="width: 100%; border-collapse: collapse;"> <thead> <tr> <th style="width: 50%;">If the component is...</th> <th style="width: 50%;">Then set...</th> </tr> </thead> <tbody> <tr> <td>Normally open</td> <td>Invert = OFF</td> </tr> <tr> <td>Normally closed</td> <td>Invert = ON</td> </tr> </tbody> </table>	If the component is...	Then set...	Normally open	Invert = OFF	Normally closed	Invert = ON		
If the component is...	Then set...								
Normally open	Invert = OFF								
Normally closed	Invert = ON								



### NOTICE

#### Invert setting for shut-off valves:

If you connect the shut-off valve (normally open or normally closed) according to one of the standard possibilities (1234), then in [13] Field IO, do NOT invert the logic (i.e. keep Invert = OFF).

If you connect the shut-off valve according to the terminal pins of any other Field IO output, then in [13] Field IO:

- In case of normally open shut-off valves: Do NOT invert the logic (i.e. keep Invert = OFF).
- In case of normally closed shut-off valves: Invert the logic (i.e. set Invert = ON).

### Field IO inputs

If the connected component is...	Then select Function = ...
Remote outdoor sensor. See addendum book for optional equipment (and "6.4 Connections to the indoor unit" ▶ 14)).	External outdoor sensor
Remote indoor sensor. See addendum book for optional equipment (and "6.4 Connections to the indoor unit" ▶ 14)).	External indoor sensor



If the connected component is...	Then select Function = ...
Smart Grid contacts. See "6.4.14 Smart Grid" ▶ 24].	HV/LV Smart Grid Contact 1
	HV/LV Smart Grid Contact 2
Preferential kWh rate power supply contact. See "6.4.2 To connect the main power supply" ▶ 18].	HP Tariff Contact
Safety thermostats for unit. See "6.4.13 To connect the safety thermostat" ▶ 23].	Safety thermostat unit
Smart Grid meter contact. See "6.4.14 Smart Grid" ▶ 24].	Smart Meter Contact











### Field IO outputs

If the connected component is...	Then select Function = ...
Shut-off valves for main zone and additional zone. See "6.4.5 To connect the shut-off valve" ▶ 20]	Main zone shut-off valve
	Add. zone shut-off valve
Alarm output. See "6.4.8 To connect the alarm output" ▶ 22].	Alarm
Changeover to external heat source. See "6.4.10 To connect the changeover to external heat source" ▶ 22].	External heat source
Bivalent bypass valve. See "6.4.11 To connect the bivalent bypass valve" ▶ 23].	Bivalent bypass valve
Space cooling/heating operation ON/OFF output for the main zone or additional zone. See "6.4.9 To connect the space cooling/heating ON/OFF output" ▶ 22].	Cooling/Heating mode
Heat pump convectors. See addendum book for optional equipment (and "6.4 Connections to the indoor unit" ▶ 14)).	DHW pump
	C/H secondary pump
	C/H pump ext. main
DHW pump + extra external pumps. See "6.4.6 To connect the pumps (DHW pump and/or external pumps)" ▶ 21].	C/H pump ext. add.
DHW ON signal. See "6.4.7 To connect the domestic hot water ON signal" ▶ 22].	DHW On signal







## 6.4 Connections to the indoor unit

Item	Description
Power supply (main)	See "6.4.2 To connect the main power supply" ▶ 18].
Power supply (backup heater)	See "6.4.3 To connect the backup heater power supply" ▶ 19]
Normally closed shut-off valve (inlet leak stop)	See "6.4.4 To connect the normally closed shut-off valve (inlet leak stop)" ▶ 20]

Item	Description
Shut-off valve	See "6.4.5 To connect the shut-off valve" [▶ 20].
Domestic hot water pump or external pumps	See "6.4.6 To connect the pumps (DHW pump and/or external pumps)" [▶ 21]
Domestic hot water ON signal	See "6.4.7 To connect the domestic hot water ON signal" [▶ 22]
Alarm output	See "6.4.8 To connect the alarm output" [▶ 22].
Space cooling/heating operation control	See "6.4.9 To connect the space cooling/heating ON/OFF output" [▶ 22].
Changeover to external heat source control	See "6.4.10 To connect the changeover to external heat source" [▶ 22].
Bivalent bypass valve	See "6.4.11 To connect the bivalent bypass valve" [▶ 23]
Electricity meters	See "6.4.12 To connect the electricity meters" [▶ 23].
Safety thermostat	See "6.4.13 To connect the safety thermostat" [▶ 23].
Smart Grid	See "6.4.14 Smart Grid" [▶ 24].
WLAN cartridge	See "6.4.15 To connect the WLAN cartridge (delivered as accessory)" [▶ 26] .
Ethernet (Modbus) cable	See "6.4.16 To connect the Ethernet (Modbus) cable" [▶ 26].
Solar input	See "6.4.17 To connect the solar input" [▶ 27].
Gas meter	See "6.4.18 To connect the gas meter" [▶ 27]
Room thermostat (wired or wireless)	 See below table.
	 Wires: 0.75 mm <sup>2</sup> Maximum running current: 100 mA
	 For the main zone: <ul style="list-style-type: none"> <li>▪ [1.12] Control</li> <li>▪ [1.13] External room thermostat</li> </ul> For the additional zone: <ul style="list-style-type: none"> <li>▪ [2.12] Control</li> <li>▪ [2.13] External room thermostat</li> </ul>

Item	Description
Heat pump convector	 There are different controllers and setups possible for the heat pump convectors.  Depending on the setup, implement a relay (field supply, see addendum book for optional equipment).  For more information, see: <ul style="list-style-type: none"> <li>▪ Installation manual of the heat pump convectors</li> <li>▪ Installation manual of the heat pump convector options</li> <li>▪ Addendum book for optional equipment</li> </ul>
	 Wires: 0.75 mm <sup>2</sup> Maximum running current: 100 mA  This is a Field IO output connection. See "6.3 Field IO connections" [▶ 13].
	 [13] Field IO (Cooling/Heating mode)  For the main zone: <ul style="list-style-type: none"> <li>▪ [1.12] Control</li> <li>▪ [1.13] External room thermostat</li> </ul> For the additional zone: <ul style="list-style-type: none"> <li>▪ [2.12] Control</li> <li>▪ [2.13] External room thermostat</li> </ul>
	 See: <ul style="list-style-type: none"> <li>▪ Installation manual of the remote outdoor sensor</li> <li>▪ Addendum book for optional equipment</li> </ul>
Remote outdoor sensor	 Wires: 2×0.75 mm <sup>2</sup>  This is a Field IO input connection. See "6.3 Field IO connections" [▶ 13].
	 [13] Field IO (External outdoor sensor)  [5.22] External ambient sensor offset
	 See: <ul style="list-style-type: none"> <li>▪ Installation manual of the remote indoor sensor</li> <li>▪ Addendum book for optional equipment</li> </ul>
Remote indoor sensor	 Wires: 2×0.75 mm <sup>2</sup>  This is a Field IO input connection. See "6.3 Field IO connections" [▶ 13].
	 [13] Field IO (External indoor sensor)  [1.33] External room sensor offset
	 See: <ul style="list-style-type: none"> <li>▪ Installation manual of the remote indoor sensor</li> <li>▪ Addendum book for optional equipment</li> </ul>

## 6 Electrical installation

Item	Description
Human Comfort Interface	 See: <ul style="list-style-type: none"> <li>Installation and operation manual of the Human Comfort Interface</li> <li>Addendum book for optional equipment</li> </ul>
	 Wires: 2×(0.75~1.25 mm <sup>2</sup> ) Maximum length: 500 m
	 [1.12] Control  [1.38] Room sensor offset
Bizone kit	 See: <ul style="list-style-type: none"> <li>Installation manual of the bizone kit</li> <li>Addendum book for optional equipment</li> </ul>
	 Use the cable delivered with the bizone kit.
	 [3.13.5] Bizone kit installed

 for room thermostat (wired or wireless):

In case of...	See...
Wireless room thermostat	<ul style="list-style-type: none"> <li>Installation manual of the wireless room thermostat</li> <li>Addendum book for optional equipment</li> </ul>
Wired room thermostat without multi-zoning base unit	<ul style="list-style-type: none"> <li>Installation manual of the wired room thermostat</li> <li>Addendum book for optional equipment</li> </ul>
Wired room thermostat with multi-zoning base unit	<ul style="list-style-type: none"> <li>Installation manual of the wired room thermostat (digital or analogue) + multi-zoning base unit</li> <li>Addendum book for optional equipment</li> <li>In this case:               <ul style="list-style-type: none"> <li>You need to connect the wired room thermostat (digital or analogue) to the multi-zoning base unit</li> <li>You need to connect the multi-zoning base unit to the outdoor unit</li> <li>For cooling/heating operation, you also need to implement a relay (field supply, see addendum book for optional equipment)</li> </ul> </li> </ul>

### 6.4.1 To connect the electrical wiring to the indoor unit

**Remark:** All cables which will be connected to the switch box of the ECH<sub>2</sub>O must be fixed by strain relief.

To have easier access to the switch box itself and the routing of cables the switch box can be lowered (see "4.2.1 To open the indoor unit" ▶ 5).

### NOTICE

If the switch box is lowered in service position while the electrical installation is done, additional cable length has to be taken into account adequately. The cable routing in normal position is longer than in service position.

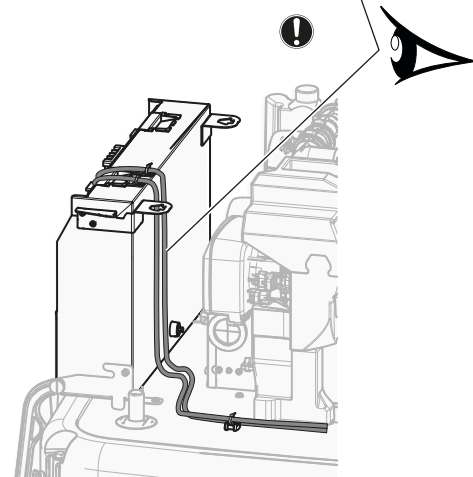
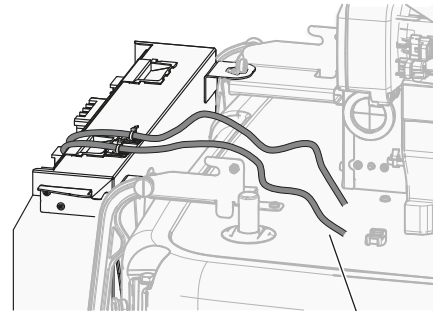

### Cable fixation for strain relief

Install the cable with cable fixation and cable tie on the top of the switch box as follows:

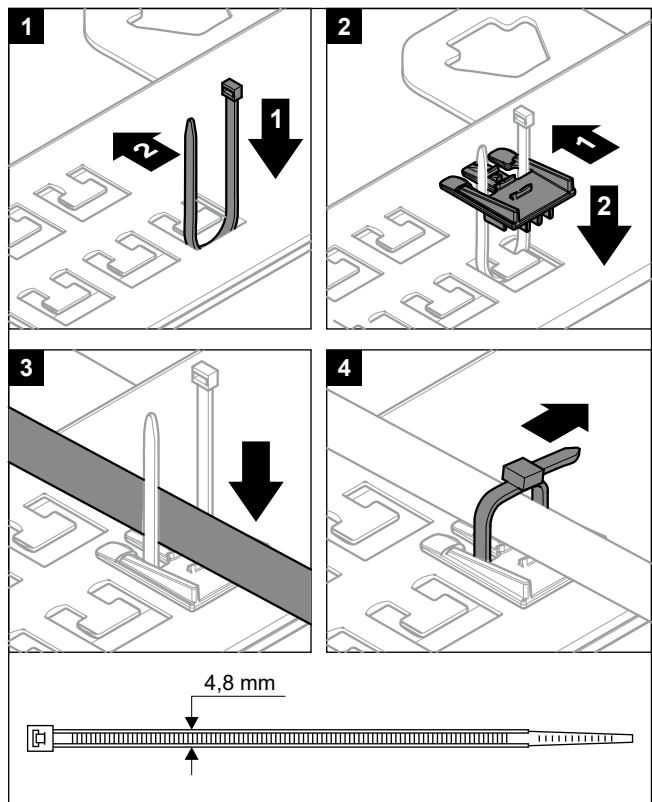



It is not allowed to connect cables to the terminals while the mounting plate for the terminals is in the service position.

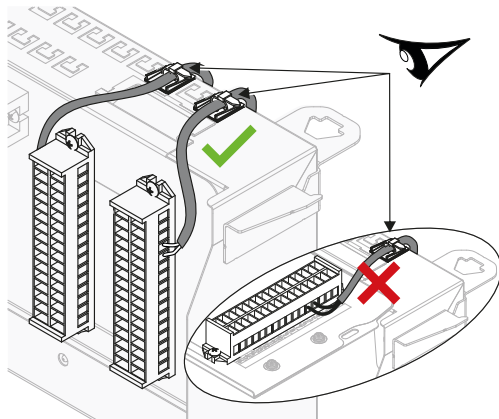

### Cable routing

**Note:** For the Ethernet (Modbus) cable, see "6.4.16 To connect the Ethernet (Modbus) cable" [p. 26].

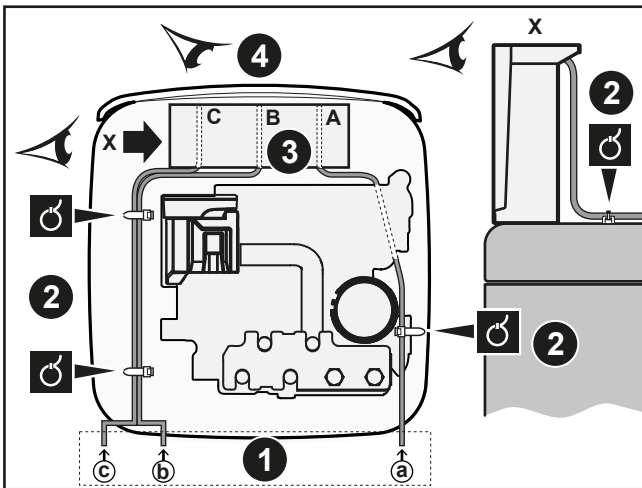

- 1 Entry into unit
- 2 Strain relief (cable ties)
- 3 Entry into switch box + strain relief (cable ties or cable glands)
- 4 Front view switch box (terminal blocks and PCBs)

Follow cable route **a**→:

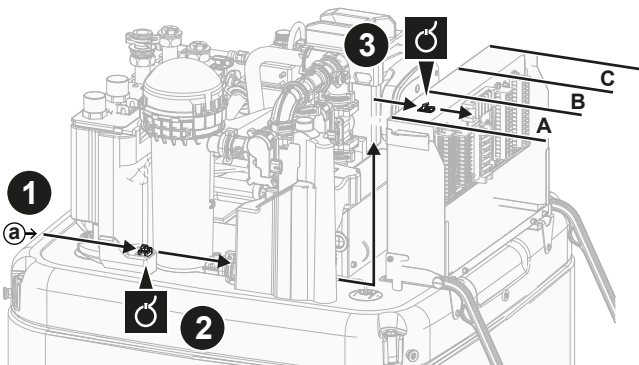

Follow cable route **b**→ and **c**→:

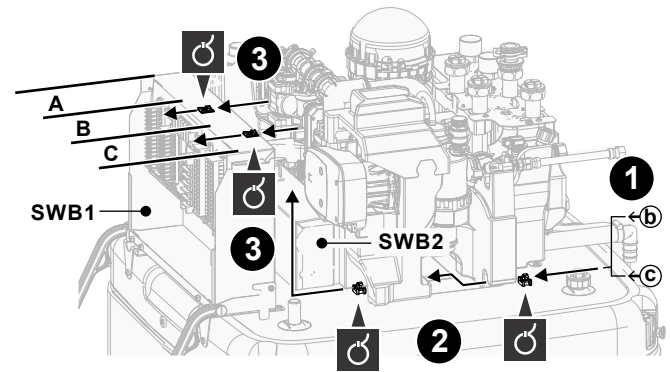

### Terminal blocks (SWB1)

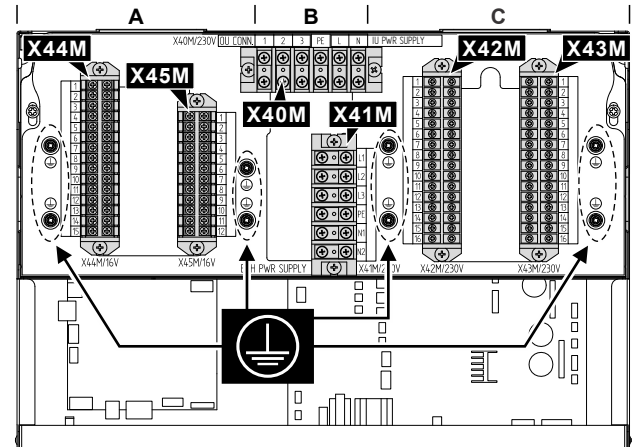

#	Cable	Terminal block
A	Low voltage options:	X44M+ X45M
	▪ Preferential power supply contact (field supply)	
	▪ Human Comfort Interface (option kit)	
	▪ Outdoor ambient temperature sensor (option kit)	
	▪ Indoor ambient temperature sensor (option kit)	
	▪ Electrical meters (field supply)	
	▪ Safety thermostat (field supply)	
	▪ Smart Grid (low voltage contacts) (field supply)	
B	Main power supply	X40M
	Interconnection cable	X40M
	Backup heater power supply	X41M

## 6 Electrical installation

#	Cable	Terminal block
C	High voltage options: <ul style="list-style-type: none"> <li>Heat pump convector (option kit)</li> <li>Room thermostat (option kit)</li> <li>Shut-off valve (field supply)</li> <li>Domestic hot water pump + extra external pumps (field supply)</li> <li>Domestic hot water ON signal (field supply)</li> <li>Alarm output (field supply)</li> <li>Changeover to external heat source control (field supply)</li> <li>Bivalent bypass pass valve (field supply)</li> <li>Space heat/cool operation control (field supply)</li> <li>Smart Grid (high voltage contacts) (option kit)</li> </ul>	X42M + X43M

PCBs (inside the switch boxes):

SWB1

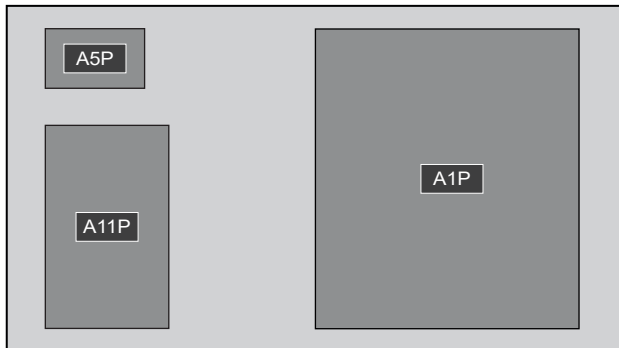

SWB2



Switchbox	PCB
SWB1	<ul style="list-style-type: none"> <li>A1P: Hydro PCB</li> <li>A5P: Power supply PCB</li> <li>A11P: Interface PCB</li> </ul>
SWB2	<ul style="list-style-type: none"> <li>A6P: Multistep backup heater PCB</li> <li>Q1L: Thermal protector backup heater</li> </ul>

### INFORMATION

When installing field supply or option cables, foresee sufficient cable length. This will make it possible to remove/reposition the switch box and gain access to other components during service.

### CAUTION

Do NOT push or place redundant cable length into the unit.

### 6.4.2 To connect the main power supply

This chapter describes 2 possible ways to connect the main power supply:

- In case of indoor unit supplied separately:
  - with normal kWh rate power supply
  - with preferential kWh rate power supply
- In case of indoor unit supplied from the outdoor unit

In case of indoor unit supplied separately (Standard):

#### Specifications of wiring components

Normal kWh rate power supply for the indoor unit (= main power supply)	
Maximum running current	6,3 A
Voltage	220-240 V
Phase	1~
Frequency	50 Hz
Wire size	MUST comply with national wiring regulation. Wire size based on the current, but not less than 1.5 mm <sup>2</sup> 3-core cable
Recommended field fuse	6 A
Earth leakage circuit breaker	30 mA – MUST comply with national wiring regulation  MUST be compatible with the harmonic currents produced by the unit

With normal kWh rate power supply

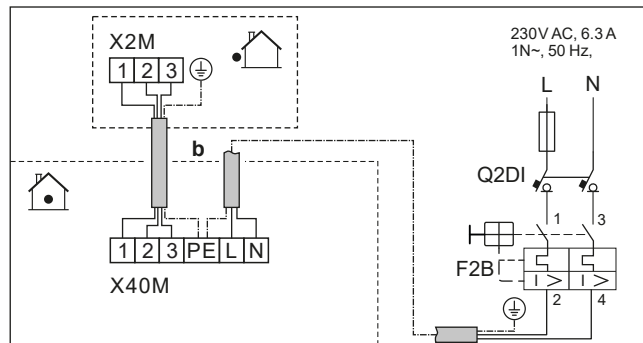
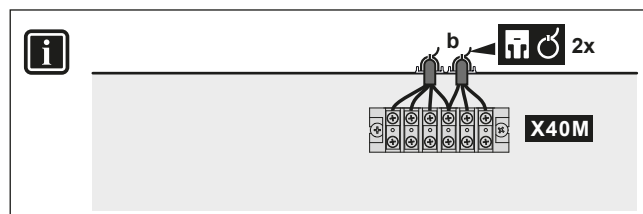

b	Interconnection cable	<ul style="list-style-type: none"> <li>Follow cable route (b) in "6.4.1 To connect the electrical wiring to the indoor unit" [p. 16].</li> <li>Wires: (3+GND)×1.5 mm<sup>2</sup></li> </ul>
	Indoor unit power supply (= main power supply)	<ul style="list-style-type: none"> <li>Follow cable route (b) in "6.4.1 To connect the electrical wiring to the indoor unit" [p. 16].</li> <li>Wires: 1N + GND</li> <li>F2B: Overcurrent fuse (field supply)</li> <li>Q2DI: Earth leakage circuit breaker (field supply)</li> </ul>

## With preferential kWh rate power supply

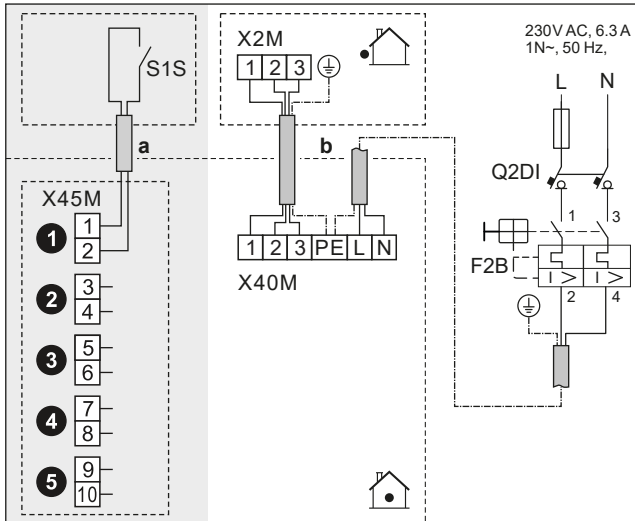
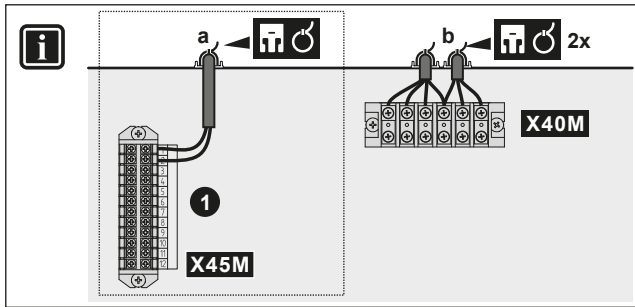

	<b>a</b> Preferential kWh rate power supply contact (S1S)	<ul style="list-style-type: none"> <li>Follow cable route <b>a</b> in "6.4.1 To connect the electrical wiring to the indoor unit"   16].</li> <li>Wires: 2x(0.75~1.25 mm<sup>2</sup>)</li> <li>Maximum length: 50 m.</li> <li>Preferential kWh rate power supply contact: 16 V DC detection (voltage supplied by PCB). The voltage-free contact shall ensure the minimum applicable load of 15 V DC, 10 mA.</li> <li>This is a Field IO input connection. See "6.3 Field IO connections"   13].</li> </ul>
	<b>b</b> Interconnection cable	<ul style="list-style-type: none"> <li>Follow cable route <b>b</b> in "6.4.1 To connect the electrical wiring to the indoor unit"   16].</li> <li>Wires: (3+GND)x1.5 mm<sup>2</sup></li> </ul>
	Indoor unit power supply (= main power supply)	<ul style="list-style-type: none"> <li>Follow cable route <b>b</b> in "6.4.1 To connect the electrical wiring to the indoor unit"   16].</li> <li>Wires: 1N + GND</li> <li>F2B: Overcurrent fuse (field supply)</li> <li>Q2DI: Earth leakage circuit breaker (field supply)</li> </ul>
	<ul style="list-style-type: none"> <li>[13] Field IO (HP Tariff Contact)</li> <li>[9.14.1] Operation mode (Heat pump tariff)</li> </ul>	

## In case of indoor unit supplied from the outdoor unit

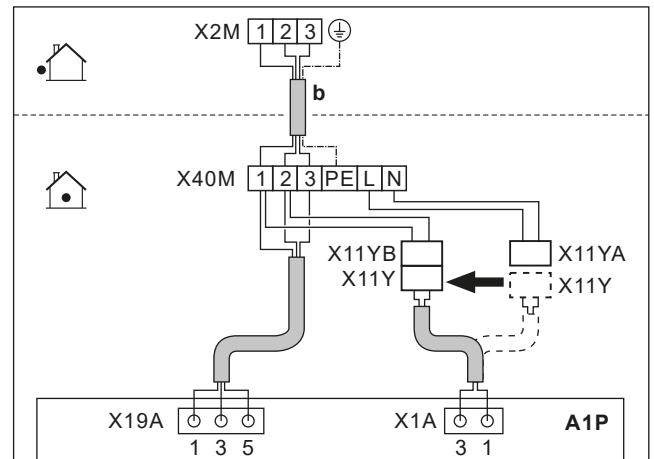
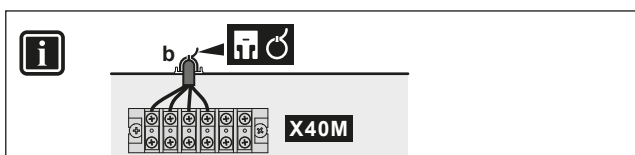

	<b>b</b> Interconnection cable (= main power supply)	<ul style="list-style-type: none"> <li>Follow cable route <b>b</b> in "6.4.1 To connect the electrical wiring to the indoor unit"   16].</li> <li>Wires: (3+GND)x1.5 mm<sup>2</sup></li> </ul>
	<b>X11Y</b>	<ul style="list-style-type: none"> <li>Disconnect X11Y from X11YA.</li> <li>Connect X11Y to X11YB.</li> </ul>

## 6.4.3 To connect the backup heater power supply



### WARNING

The backup heater MUST have a dedicated power supply and MUST be protected by the safety devices required by the applicable legislation.



### CAUTION

To guarantee the unit is completely earthed, ALWAYS connect the backup heater power supply and the earth cable.



### NOTICE

If the backup heater is not powered, then:

- Space heating and tank heat-up is not allowed.
- Error AA-01 (Backup heater overheated or BUH power cable not connected) is generated.



### NOTICE

The output of the backup heater depends on the wiring and the selection in the user interface. Make sure that the power supply matches the selection in the user interface.

## Possible layouts in case of 9 kW multistep backup heater

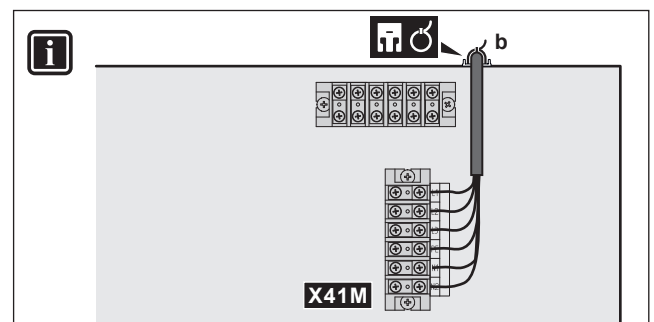

## 6 Electrical installation

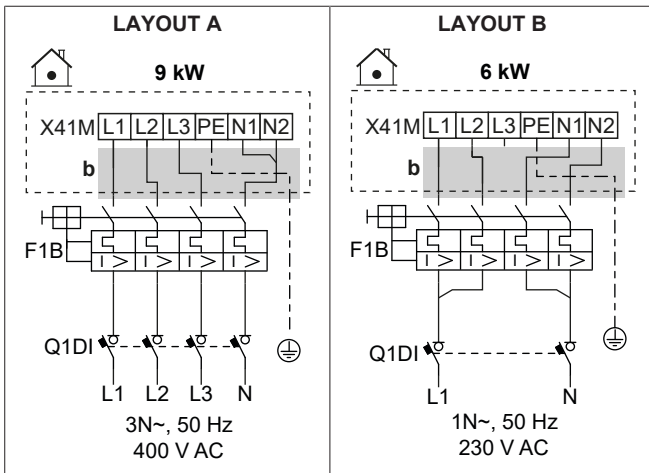

	<b>b</b>	Follow cable route (b) in "6.4.1 To connect the electrical wiring to the indoor unit" [▶ 16].
	F1B	Overcurrent fuse (field supply). Rating in tables.
	Q1DI	Earth leakage circuit breaker (field supply)
	[5.5] Backup heater	

### Specifications of wiring components

Component	LAYOUT	
	A	B
Power supply		
Voltage	390-410 V	220-240 V
Power	9 kW	6 kW
Rated current	13 A	13 A
Phase	3N~	1N~
Frequency	50 Hz	
Wire size	MUST comply with national wiring regulation Wire size based on the current, but minimum 2.5 mm <sup>2</sup> 5-core cable 3L+N+GND      2L+2N+GND	
Recommended overcurrent fuse	4-pole 16A	
Earth leakage circuit breaker	MUST comply with national wiring regulation <sup>(a)</sup>	

<sup>(a)</sup> A rated residual operating current not exceeding 30 mA is advisable.

### 6.4.4 To connect the normally closed shut-off valve (inlet leak stop)

#### NOTICE

The shut-off valve (inlet leak stop) is equipped with an anti-blockage safety routine. To enable this routine, the unit must be connected to the power supply all year round. This routine operates as follows every 14 days after the last execution:

- If the unit is not operational, the anti-blockage safety routine is executed (i.e. the valve closes for a short period of time).
- If the unit is operational, the anti-blockage safety routine is postponed for a maximum of 7 days. If the unit is still operational after these 7 days, the unit will be temporarily forced to stop in order to execute the anti-blockage safety routine.

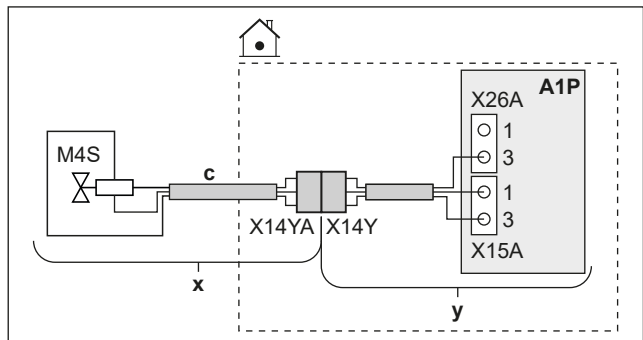

	<b>x</b>	Delivered as accessory
	<b>y</b>	Factory-mounted
	<b>c</b>	Follow cable route (c) in "6.4.1 To connect the electrical wiring to the indoor unit" [▶ 16].
	M4S	Normally closed shut-off valve (inlet leak stop)
	X14Y	Connect X14YA to X14Y.

### 6.4.5 To connect the shut-off valve

#### NOTICE

Wiring is different for a NC (normally closed) valve and a NO (normally open) valve.

#### INFORMATION

**Shut-off valve usage example.** In case of one LWT zone, and a combination of underfloor heating and heat pump convectors, install a shut-off valve before the underfloor heating to prevent condensation on the floor during cooling operation.

#### NOTICE

Invert **setting for shut-off valves:**

If you connect the shut-off valve (normally open or normally closed) according to one of the standard possibilities (1 2 3 4), then in [13] Field IO, do NOT invert the logic (i.e. keep Invert = OFF).

If you connect the shut-off valve according to the terminal pins of any other Field IO output, then in [13] Field IO:

- In case of normally open shut-off valves: Do NOT invert the logic (i.e. keep Invert = OFF).
- In case of normally closed shut-off valves: Invert the logic (i.e. set Invert = ON).

### In case of normally closed shut-off valves

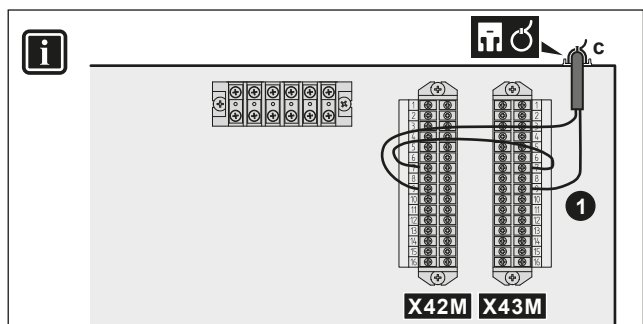

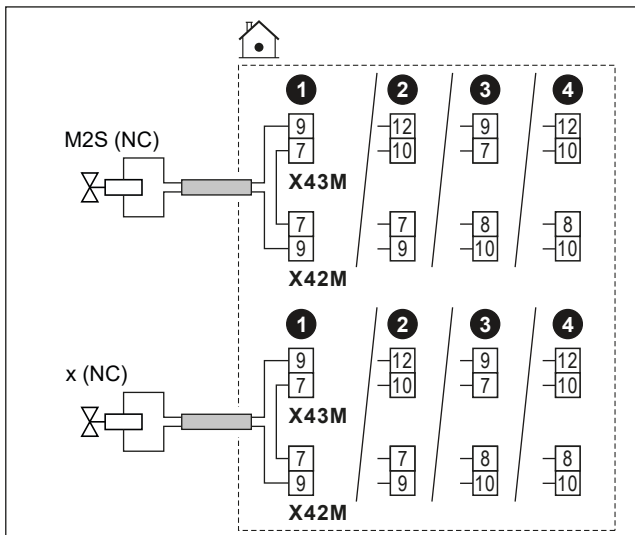

In case of normally open shut-off valves

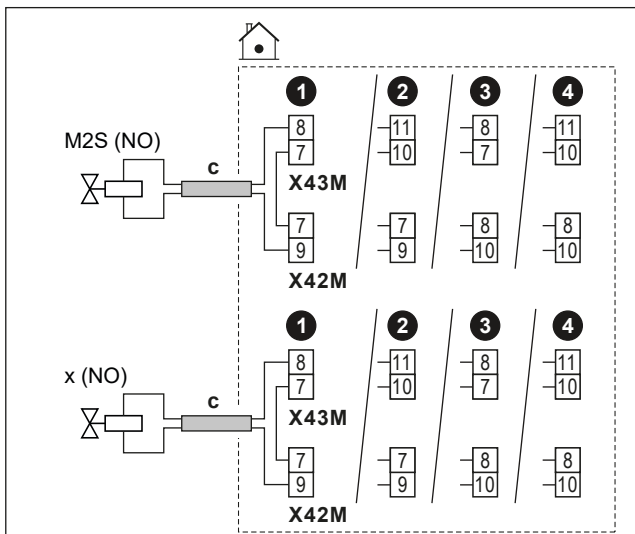
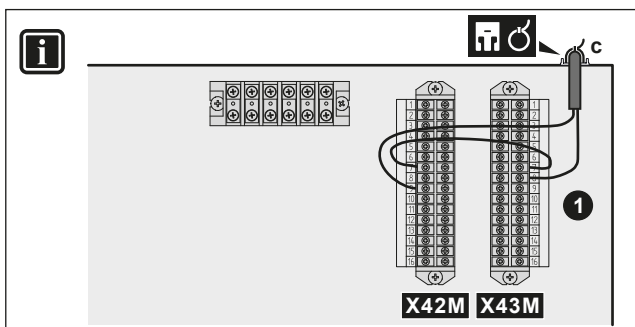

	<b>c</b>	<ul style="list-style-type: none"> <li>Follow cable route  in "6.4.1 To connect the electrical wiring to the indoor unit" [▶ 16].</li> <li>Wires: (2 + bridge)×1 mm<sup>2</sup></li> <li>This is a Field IO output connection. See "6.3 Field IO connections" [▶ 13].</li> </ul>
	M2S	Shut-off valve for the main zone Maximum running current: 0.3 A
	x	Shut-off valve for the additional zone 230 V AC supplied by PCB
	NC	Normally closed
	NO	Normally open
	[13] Field IO:	<ul style="list-style-type: none"> <li>Main zone shut-off valve</li> <li>Add. zone shut-off valve</li> </ul>

### 6.4.6 To connect the pumps (DHW pump and/or external pumps)

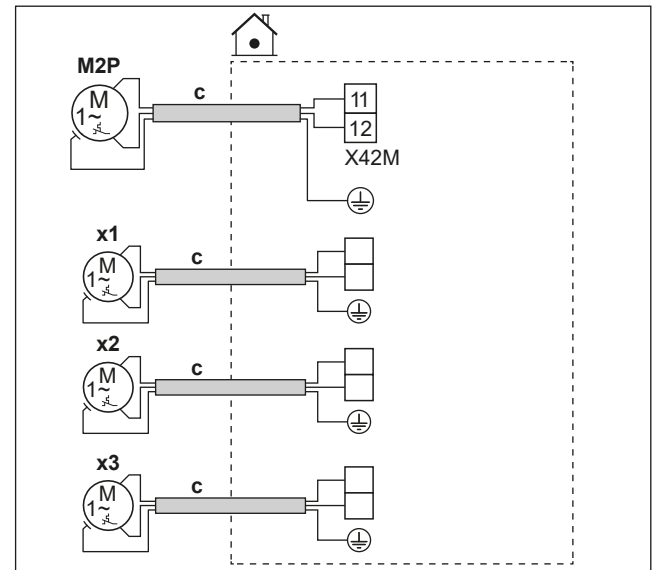
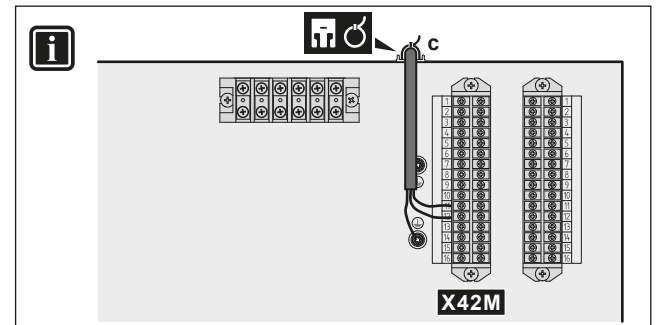

	<b>c</b>	<ul style="list-style-type: none"> <li>Follow cable route  in "6.4.1 To connect the electrical wiring to the indoor unit" [▶ 16].</li> <li>Wires: (2+GND)×1 mm<sup>2</sup></li> <li>This is a Field IO output connection. See "6.3 Field IO connections" [▶ 13].</li> </ul>
	M2P	DHW pump output. Maximum load: 2 A (inrush), 230 V AC, 1 A (continuous)
	x1	Extra external pumps
	x2	
	x3	
	[13] Field IO	<ul style="list-style-type: none"> <li>DHW pump: Pump used for instant hot water and/or disinfection operation. In this case you must also specify the functionality in setting [4.13] DHW pump:                         <ul style="list-style-type: none"> <li>* Instant hot water</li> <li>* Disinfection</li> <li>* Both</li> </ul> </li> <li>C/H secondary pump: Pump runs when there is a request from the main or additional zone.</li> <li>C/H pump ext. main: Pump runs when there is a request from the main zone.</li> <li>C/H pump ext. add.: Pump runs when there is a request from the additional zone.</li> </ul>
		Use the terminal pins of any of the other Field IO outputs. However, you must also check if you need to install a relay in-between.
		[4.26] DHW pump schedule

## 6 Electrical installation

### 6.4.7 To connect the domestic hot water ON signal

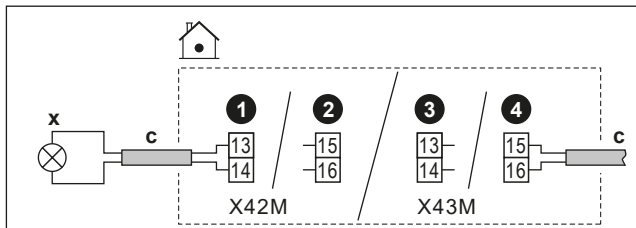
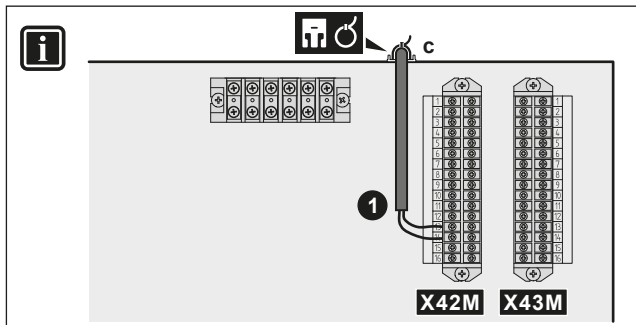

	<b>c</b>	<ul style="list-style-type: none"> <li>Follow cable route  in "6.4.1 To connect the electrical wiring to the indoor unit" <a href="#">▶ 16</a>].</li> <li>Wires: 2×1 mm<sup>2</sup></li> <li>This is a Field IO output connection. See "6.3 Field IO connections" <a href="#">▶ 13</a>].</li> </ul>
	<b>x</b>	Domestic hot water ON signal (= unit is running in DHW operation): <ul style="list-style-type: none"> <li>Maximum load: 0.3 A, 230 V AC</li> </ul>
		<ul style="list-style-type: none"> <li>[13] Field IO (DHW On signal)</li> </ul>

### 6.4.8 To connect the alarm output

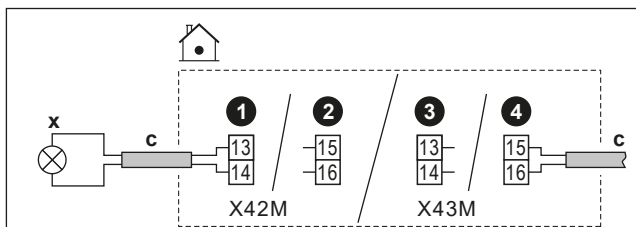
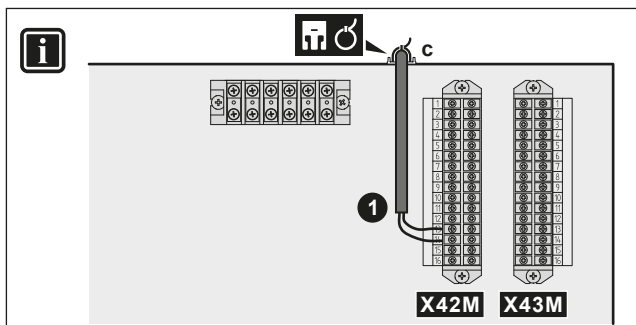

	<b>c</b>	<ul style="list-style-type: none"> <li>Follow cable route  in "6.4.1 To connect the electrical wiring to the indoor unit" <a href="#">▶ 16</a>].</li> <li>Wires: 2×1 mm<sup>2</sup></li> <li>This is a Field IO output connection. See "6.3 Field IO connections" <a href="#">▶ 13</a>].</li> </ul>
	<b>x</b>	Alarm output: <ul style="list-style-type: none"> <li>Maximum load: 0.3 A, 230 V AC</li> </ul>
		<ul style="list-style-type: none"> <li>[13] Field IO (Alarm)</li> </ul>

### 6.4.9 To connect the space cooling/heating ON/OFF output

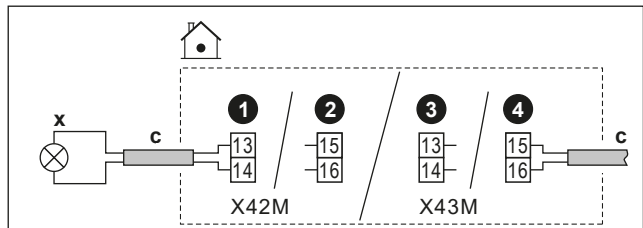
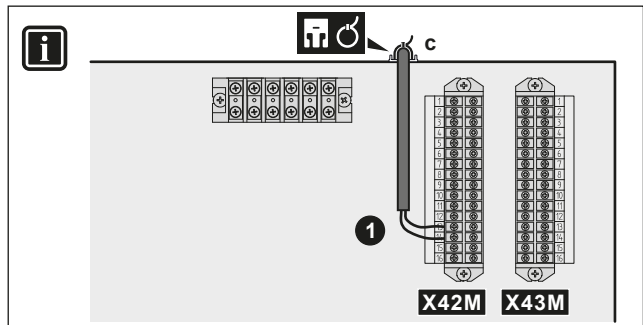

	<b>c</b>	<ul style="list-style-type: none"> <li>Follow cable route  in "6.4.1 To connect the electrical wiring to the indoor unit" <a href="#">▶ 16</a>].</li> <li>Wires: 2×1 mm<sup>2</sup></li> <li>This is a Field IO output connection. See "6.3 Field IO connections" <a href="#">▶ 13</a>].</li> </ul>
	<b>x</b>	Space cooling/heating ON/OFF output: <ul style="list-style-type: none"> <li>Maximum load: 0.3 A, 230 V AC</li> </ul>
		<ul style="list-style-type: none"> <li>[13] Field IO (Cooling/Heating mode)</li> </ul>

### 6.4.10 To connect the changeover to external heat source

#### INFORMATION

Bivalent is only possible in case of 1 leaving water temperature zone with:

- room thermostat control, OR
- external room thermostat control.

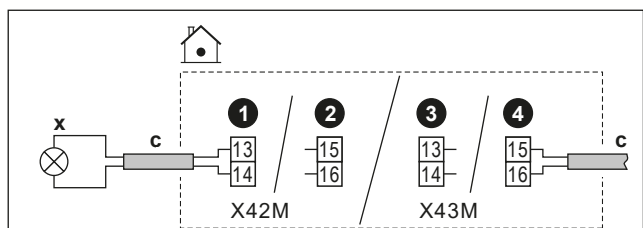
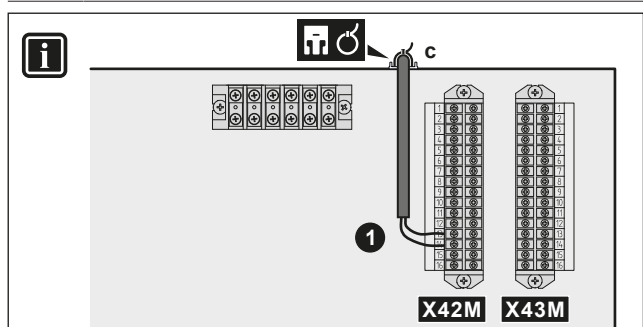

	<b>c</b>	<ul style="list-style-type: none"> <li>Follow cable route  in "6.4.1 To connect the electrical wiring to the indoor unit" <a href="#">▶ 16</a>].</li> <li>Wires: 2×1 mm<sup>2</sup></li> <li>This is a Field IO output connection. See "6.3 Field IO connections" <a href="#">▶ 13</a>].</li> </ul>
	<b>x</b>	<p>Changeover to external heat source:</p> <ul style="list-style-type: none"> <li>Maximum load: 0.3 A, 230 V AC</li> <li>Minimum load: 20 mA, 5 V DC</li> </ul>
		<ul style="list-style-type: none"> <li>[13] Field IO (External heat source)</li> <li>[5.14] Bivalent</li> <li>[5.37] Bivalent present (ON)</li> </ul>

### 6.4.11 To connect the bivalent bypass valve



**NOTICE**

Wiring is different for a NC (normally closed) valve and a NO (normally open) valve.

#### In case of normally closed bivalent bypass valves

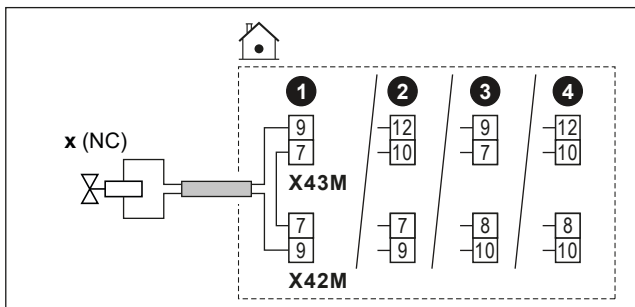

#### In case of normally open bivalent bypass valves

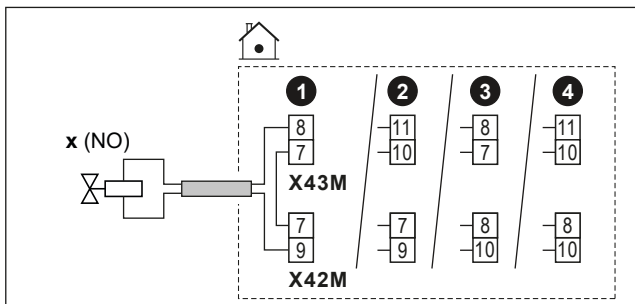

	<b>c</b>	<ul style="list-style-type: none"> <li>Follow cable route  in "6.4.1 To connect the electrical wiring to the indoor unit" <a href="#">▶ 16</a>].</li> <li>Wires: (2 + bridge)×1 mm<sup>2</sup></li> <li>This is a Field IO output connection. See "6.3 Field IO connections" <a href="#">▶ 13</a>].</li> </ul>
	<b>x</b>	<p>Bivalent bypass valve (activated when bivalent is active):</p> <ul style="list-style-type: none"> <li>Maximum running current: 0.3 A</li> <li>230 V AC supplied by PCB</li> </ul>
	NC	Normally closed
	NO	Normally open
		<ul style="list-style-type: none"> <li>[13] Field IO (Bivalent bypass valve)</li> <li>[5.14] Bivalent</li> <li>[5.37] Bivalent present (ON)</li> </ul>

### 6.4.12 To connect the electricity meters



**INFORMATION**

This functionality is NOT available in early versions of the user interface software.

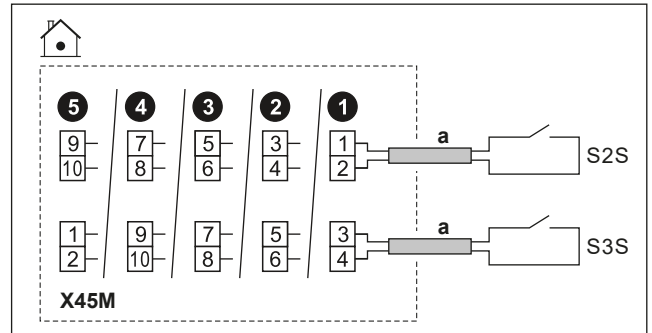
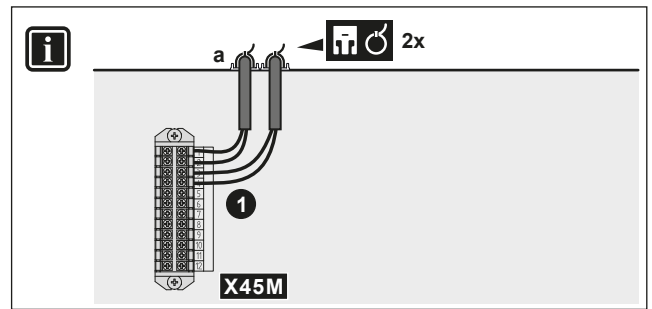

- a**
- Follow cable route in "6.4.1 To connect the electrical wiring to the indoor unit" [▶ 16](#)].
  - Wires: 2 (per meter)×0.75 mm<sup>2</sup>
  - This is a Field IO input connection. See "6.3 Field IO connections" [▶ 13](#)].

S2S	Electricity meter 1	16 V DC pulse detection
S3S	Electricity meter 2	(voltage supplied by PCB)



### 6.4.13 To connect the safety thermostat

Connect a safety thermostat to the unit, to prevent that too high temperatures go to the respective zone.

**Remark:** In case of 2 LWT zones with a bizona kit, you need to connect a second safety thermostat (for the main zone) to the bizona kit control box (EKMIKPOA), to prevent that too high temperatures go to the main zone.

For more information about the safety thermostat for the main zone, see the application guidelines in the installer reference guide.



**NOTICE**

Make sure to select and install the safety thermostat according to the applicable legislation.

In any case, to prevent unnecessary tripping of the safety thermostat, we recommend the following:

- The safety thermostat is automatically resettable.
- The safety thermostat has a maximum temperature variation rate of 2°C/min.
- The safety thermostat tripping point should be selected in line with the overheating limit.
- There is a minimum distance of 2 m between the safety thermostat and the 3-way valve.

## 6 Electrical installation

### **i** INFORMATION

The maximum leaving water temperature is decided based on setting [3.12] Overheating setpoint. This limit defines the maximum leaving water **in the system**. Depending on the value of this setting, the maximum LWT setpoint will also be reduced by 5°C to allow stable control towards the setpoint.

The maximum leaving water temperature **in the main zone** is decided based on setting [1.19] Overheating water circuit, only in case [3.13.5] Bizone kit installed is enabled. This limit defines the maximum leaving water **in the main zone**. Depending on the value of this setting, the maximum LWT setpoint will also be reduced by 5°C to allow stable control towards the setpoint.

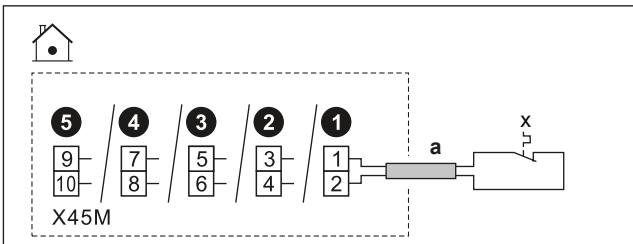
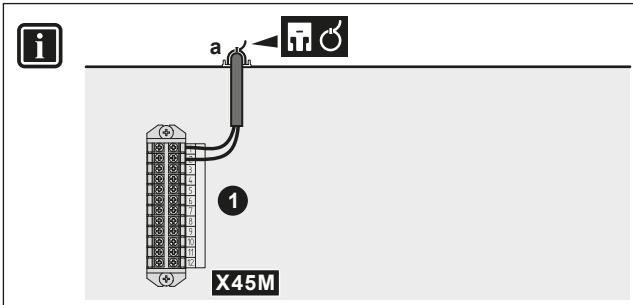

<b>w</b>	a	<ul style="list-style-type: none"> <li>Follow cable route <b>a</b> in "6.4.1 To connect the electrical wiring to the indoor unit" <a href="#">▶</a> 16].</li> <li>Wires: 2×0.75 mm<sup>2</sup></li> <li>Maximum length: 50 m</li> <li>This is a Field IO input connection. See "6.3 Field IO connections" <a href="#">▶</a> 13].</li> </ul>	
	x	<table border="0"> <tr> <td>Safety thermostat contact for the unit</td> <td>16 V DC detection (voltage supplied by PCB). The voltage-free contact shall ensure the minimum applicable load of 15 V DC, 10 mA.</td> </tr> </table>	Safety thermostat contact for the unit
Safety thermostat contact for the unit	16 V DC detection (voltage supplied by PCB). The voltage-free contact shall ensure the minimum applicable load of 15 V DC, 10 mA.		
<b>MMI</b>	[13] Field IO (Safety thermostat unit)		

### 6.4.14 Smart Grid

### **i** INFORMATION

The Smart Grid photovoltaic power pulse meter (S4S) functionality is NOT available in early versions of the user interface software.

This topic describes different ways to connect the indoor unit to a Smart Grid:

Smart Grid contacts:	The 2 incoming Smart Grid contacts can activate the following Smart Grid modes:		
<ul style="list-style-type: none"> <li>In case of low voltage Smart Grid contacts.</li> <li>In case of high voltage Smart Grid contacts. This requires the installation of <b>2 relays</b> from the Smart Grid relay kit (EKRELSG).</li> </ul>	<b>1</b>	<b>2</b>	<b>Operation mode</b>
	0	0	Free running
	0	1	Forced off
	1	0	Recommended on
1	1	Forced on	
Smart Grid meter:	If the Smart Grid meter is active, the heat pump and the additional electrical heat sources are allowed to operate if the limit allows it.		
<ul style="list-style-type: none"> <li>In case of low voltage Smart Grid meter.</li> <li>In case of high voltage Smart Grid meter. This requires the installation of <b>1 relay</b> from the Smart Grid relay kit (EKRELSG).</li> </ul>	<b>Note:</b>		
	<ul style="list-style-type: none"> <li>It is possible that in some cases this limit towards the heat pump will be ignored for reliability reasons (e.g. heat pump start-up and defrost).</li> <li>If the backup heater needs to support for protective reasons, the backup heater will kick in with at least a capacity of 2 kW (to ensure reliable operation) even if the power limit would be exceeded.</li> </ul>		

The related settings in case of **Smart Grid contacts** are as follows:

<b>MMI</b>	[13] Field IO:
	<ul style="list-style-type: none"> <li>HV/LV Smart Grid Contact 1</li> <li>HV/LV Smart Grid Contact 2</li> </ul>
	[9.14] Demand response
	[9.14.1] Operation mode (Smart grid ready contacts)

The related settings in case of **Smart Grid meter** are as follows:

<b>MMI</b>	[13] Field IO (Smart Meter Contact)
	[9.14.1] Operation mode (Smart Meter Contact)
	[9.14.7] Smart meter limit

### Connections in case of low voltage Smart Grid contacts

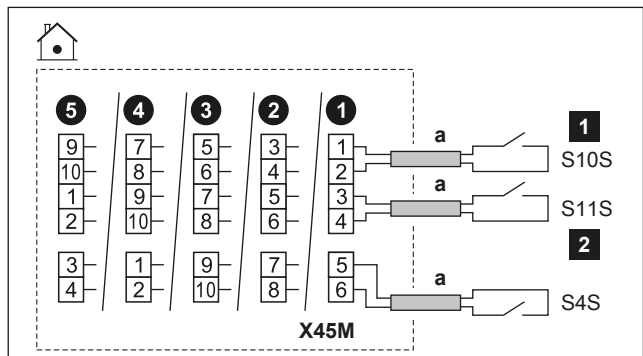

<b>w</b>	a	<ul style="list-style-type: none"> <li>Follow cable route <b>a</b> in "6.4.1 To connect the electrical wiring to the indoor unit" <a href="#">▶</a> 16].</li> <li>Wires: 0.75 mm<sup>2</sup></li> <li>This is a Field IO input connection. See "6.3 Field IO connections" <a href="#">▶</a> 13].</li> </ul>
	S4S	Smart Grid photovoltaic power pulse meter
	S10S / <b>1</b>	Low voltage Smart Grid contact 1
	S11S / <b>2</b>	Low voltage Smart Grid contact 2

### Connections in case of high voltage Smart Grid contacts

1 Install 2 relays from the Smart Grid relay kit (EKRELSG) as follows:

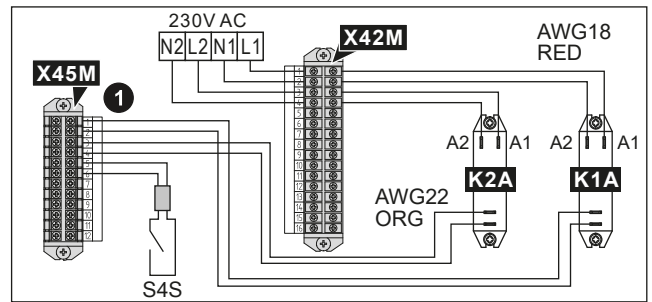
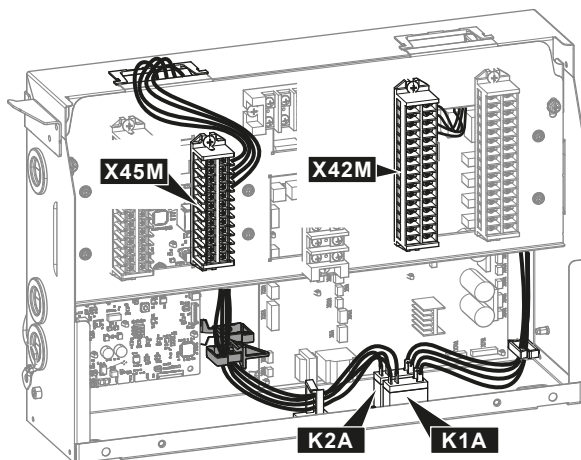
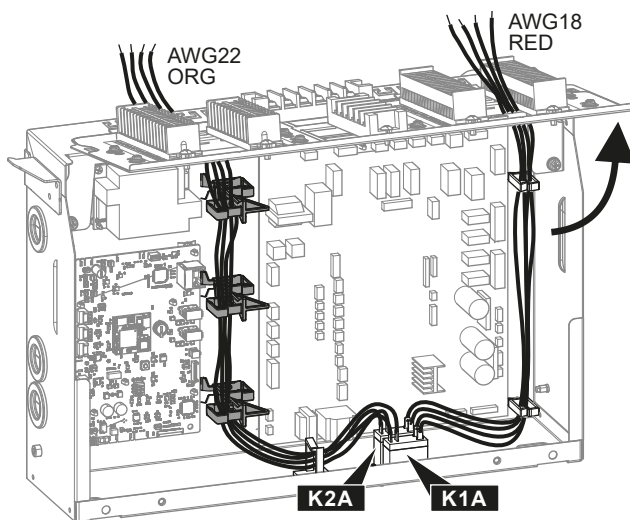
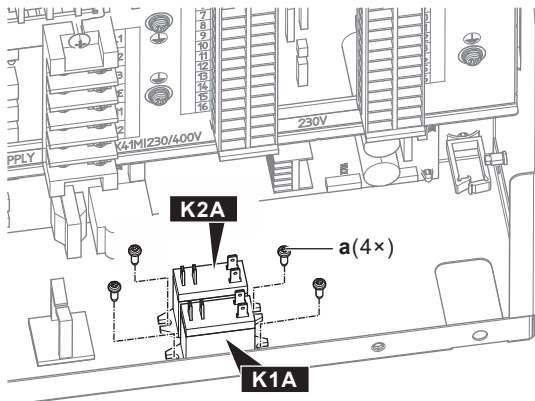
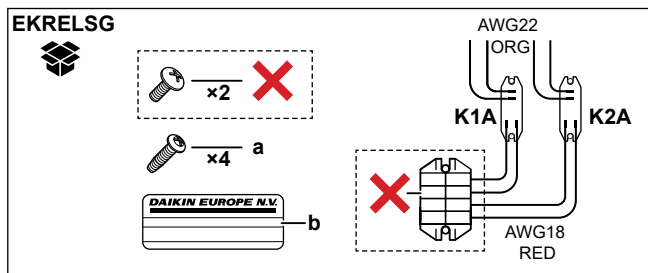

	a	Screws for K1A and K2A
	b	Sticker to put on the high voltage wires
	AWG22	Wires (AWG22 orange) coming from the contact ORG sides of the relays; to be connected to X45M
	AWG18	Wires (AWG18 red) coming from the coil sides of the relays; to be connected to X42M
	K1A, K2A	Relays
	X	NOT needed

2 Connect as follows

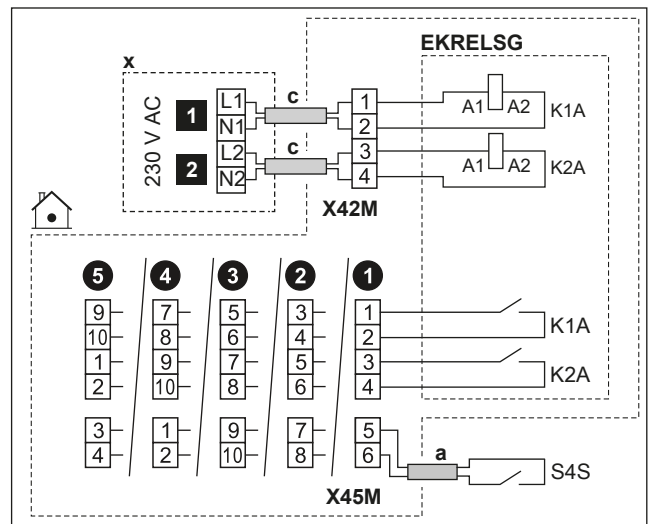

	a	<ul style="list-style-type: none"> <li>Follow cable route (a) in "6.4.1 To connect the electrical wiring to the indoor unit" [p 16].</li> <li>Wires: 0.75 mm<sup>2</sup></li> </ul>
	c	<ul style="list-style-type: none"> <li>Follow cable route (c) in "6.4.1 To connect the electrical wiring to the indoor unit" [p 16].</li> <li>Wires: 1 mm<sup>2</sup></li> </ul>
	x	230 V AC control device
	EKRELSG	Smart Grid relay kit
	G	This is a Field I/O input connection. See "6.3 Field I/O connections" [p 13].
	S4S	Smart Grid photovoltaic power pulse meter This is a Field I/O input connection. See "6.3 Field I/O connections" [p 13].
	1	High voltage Smart Grid contact 1
	2	High voltage Smart Grid contact 2

## 6 Electrical installation

### Connections in case of low voltage Smart Grid meter

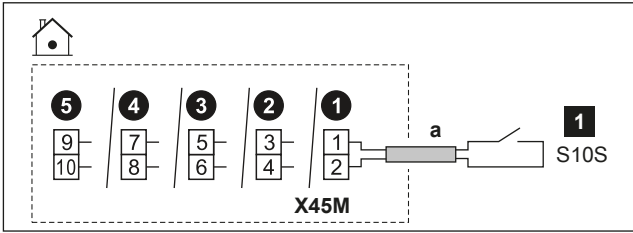

	<b>a</b>	<ul style="list-style-type: none"> <li>Follow cable route  in "6.4.1 To connect the electrical wiring to the indoor unit" [p 16].</li> <li>Wires: 0.75 mm<sup>2</sup></li> <li>This is a Field IO input connection. See "6.3 Field IO connections" [p 13].</li> </ul>
	<b>1</b>	Low voltage Smart Grid meter

### Connections in case of high voltage Smart Grid meter

- 1 Install 1 relay (K1A) from the Smart Grid relay kit (EKRELSG). (see above: Connections in case of high voltage Smart Grid contacts).
- 2 Connect as follows:

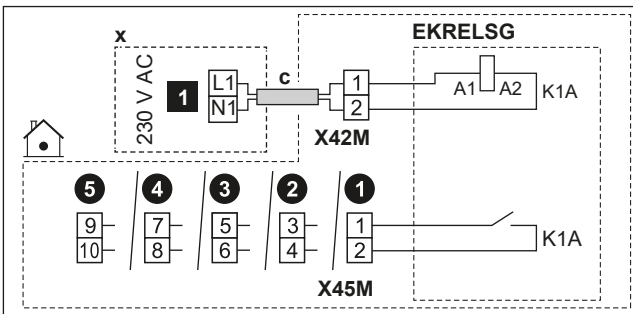

	<b>c</b>	<ul style="list-style-type: none"> <li>Follow cable route  in "6.4.1 To connect the electrical wiring to the indoor unit" [p 16].</li> <li>Wires: 1 mm<sup>2</sup></li> </ul>
	<b>x</b>	230 V AC control device
	EKRELSG	Smart Grid relay kit This is a Field IO input connection. See "6.3 Field IO connections" [p 13].
	<b>1</b>	High voltage Smart Grid meter

### 6.4.15 To connect the WLAN cartridge (delivered as accessory)

	[8.3] Wireless gateway
--	------------------------

- 1 Insert the WLAN cartridge into the cartridge slot on the user interface of the indoor unit.

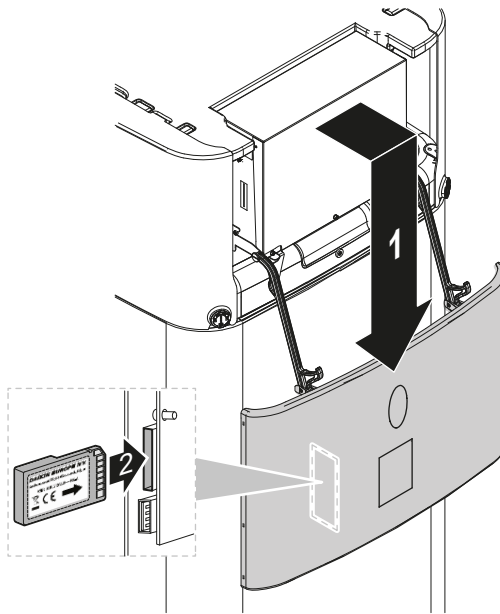

### 6.4.16 To connect the Ethernet (Modbus) cable

	Use minimum Cat 6a Ethernet cable with the following features:
	<ul style="list-style-type: none"> <li>U/UTP (= unshielded)</li> <li>Connector: RJ45 male to RJ45 male</li> </ul>
<b>Note:</b>	<ul style="list-style-type: none"> <li>It is recommended that the cable includes (moulded) strain relief to prevent damage in tight routing spaces.</li> <li>Maximum cable length: 100 m.</li> </ul>

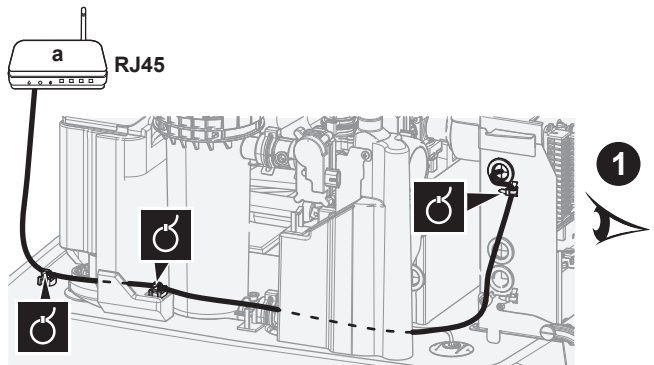

a Home router

## Routing in case of straight connector

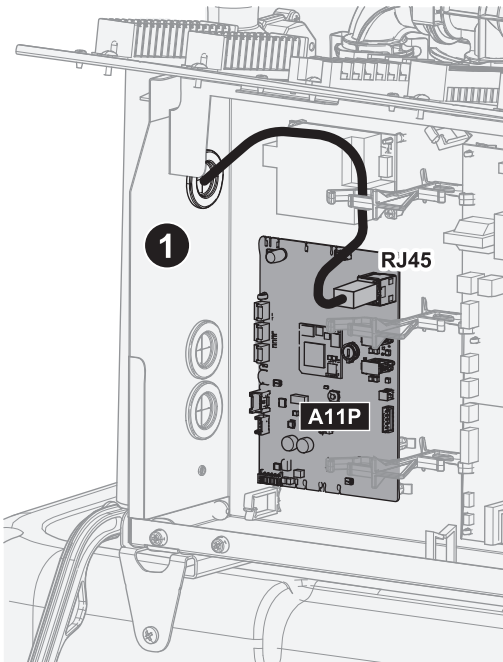

## Routing in case of 90° connector

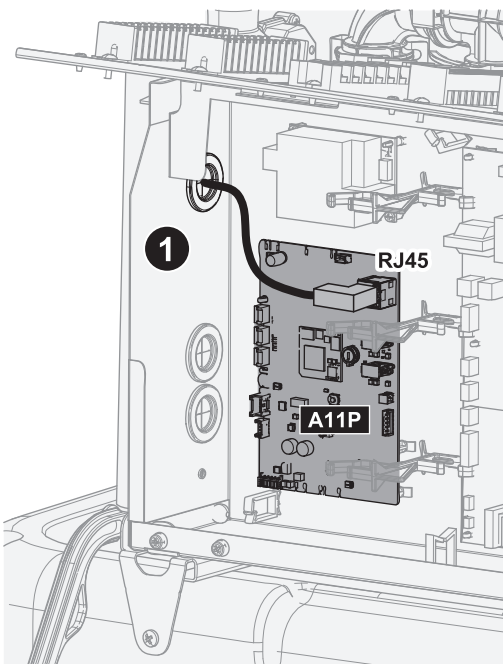

### 6.4.17 To connect the solar input



#### INFORMATION

This functionality is NOT available in early versions of the user interface software.

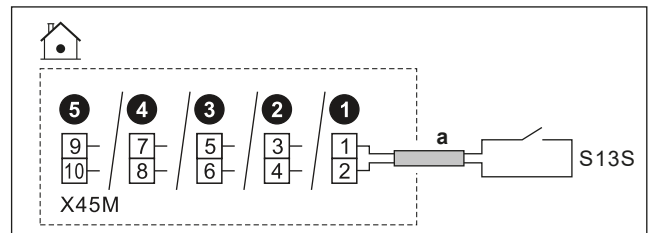
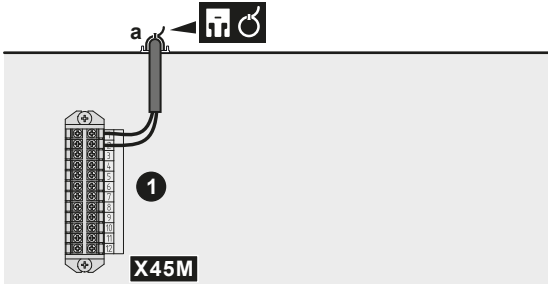

- a Follow cable route in "6.4.1 To connect the electrical wiring to the indoor unit" [ 16].
- Wires: 2x0.75 mm<sup>2</sup>
- This is a Field IO input connection. See "6.3 Field IO connections" [ 13].

S13S Gas meter: 16 V DC (voltage supplied by PCB)



### 6.4.18 To connect the gas meter



#### INFORMATION

This functionality is NOT available in early versions of the user interface software.

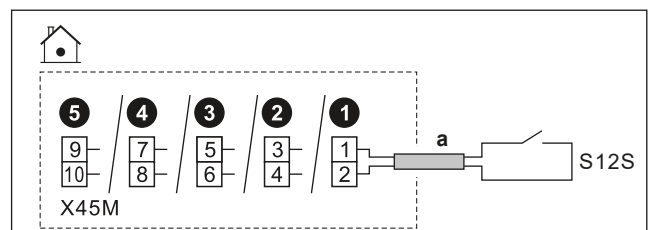
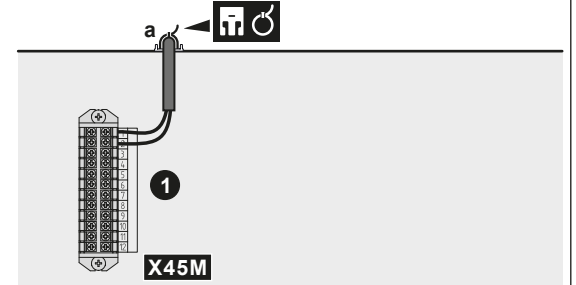

- a Follow cable route in "6.4.1 To connect the electrical wiring to the indoor unit" [ 16].
- Wires: 2x0.75 mm<sup>2</sup>
- This is a Field IO input connection. See "6.3 Field IO connections" [ 13].

S12S Gas meter: 16 V DC pulse detection (voltage supplied by PCB)



## 7 Configuration

This chapter explains only basic configuration done via the configuration wizard. For more detailed explanation and background information, see the configuration reference guide.

### User mode vs. Installer mode

On the home screen, and most other screens where applicable, you can toggle between user mode and installer mode.

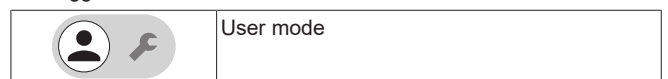

## 7 Configuration

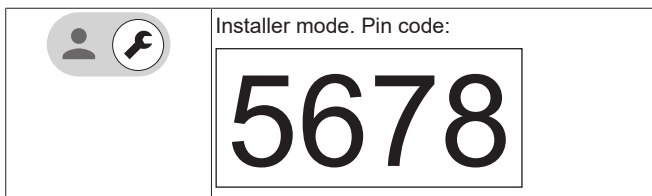

### Menu structure vs. Overview field settings

You can access the installer settings using two different methods. However, NOT all settings are accessible via both methods.

Via the menu structure (with breadcrumbs):

- 1 From the home screen, use the navigation buttons < ⏪ ⏩ ⏹ >.
- 2 Go to any of the menus:

[1] Main zone	[8] Connectivity
[2] Additional zone	[9] Energy
[3] Space heating/cooling	[10] Configuration wizard
[4] Domestic hot water	[11] Malfunctioning
[5] Settings	[12] NOT USED
[6] Information	[13] Field IO
[7] Maintenance mode	

Via the overview of the field settings:

- 1 Go to [5.7]: Settings > Overview field settings.
- 2 Go to the wanted field setting. Where applicable, the field setting codes are described in the configuration reference guide. **Example:** Go to **005** for the water pipe freeze prevention function. Field codes that are not applicable are greyed out.
- 3 Select the wanted value.

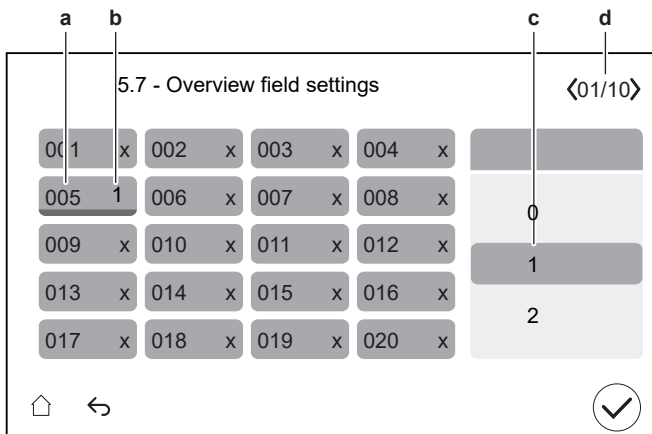

### 7.1 Configuration wizard

After first power ON of the system, the user interface starts a configuration wizard. Use this wizard to set the most important initial settings for the unit to run properly.

- If needed, you can restart the configuration wizard via the menu structure: [10] Configuration wizard.
- If needed, you can afterwards configure more settings via the menu structure.

#### Configuration wizard – Overview

Depending on your unit type and the selected settings, some steps will not be visible.

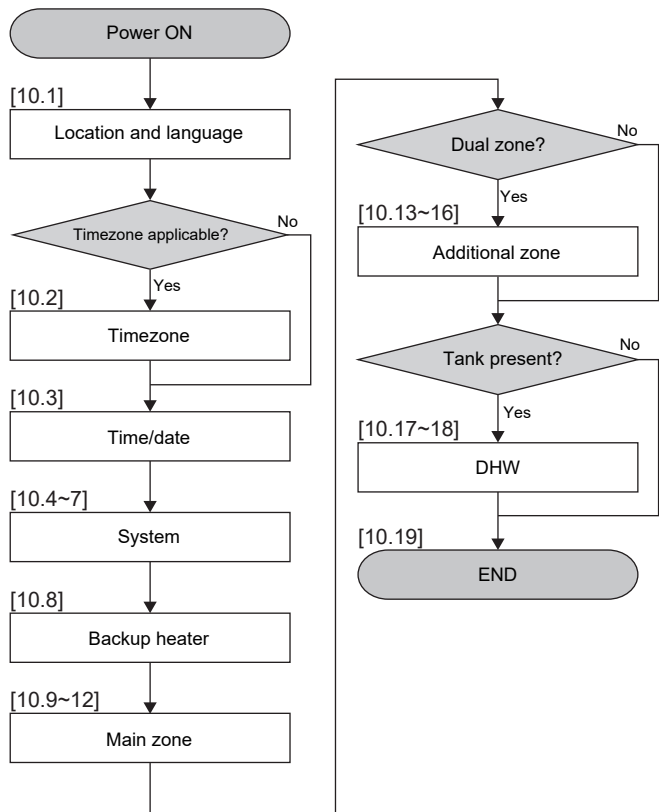

After you completed all steps in the wizard, the user interface will show an error message instructing to enter the Digital Key (i.e. perform the unlocking procedure). See ["8.2.1 To unlock the outdoor unit \(compressor\)"](#) [p 36].



#### [10.1] Location and language

Set:

- Country (this also defines the timezone if the selected country only has one timezone)
- Language

#### [10.2] Timezone

**Restriction:** This screen is only shown when there are multiple time zones within a country.

Set Timezone.

#### [10.3] Time/date

Set:

- Date
- Clock format (24 hours or AM/PM)
- Time

- Daylight savings time (ON/OFF)

### [10.4] System 1/4

Set:

- Number of zones
- Bivalent
- DHW Tank (not applicable for floor-standing units)
- DHW Tank type (not applicable for floor-standing units)

#### Number of zones

The system can supply leaving water to up to 2 water temperature zones. During configuration, the number of water zones must be set.

- Single zone

Only one leaving water temperature zone.

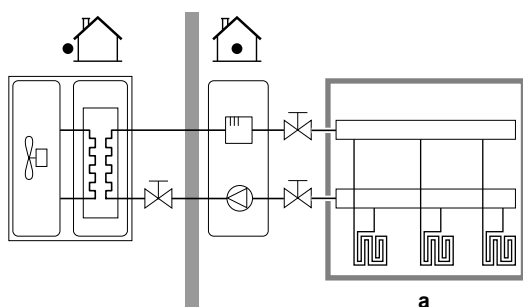

#### a Main LWT zone

- Dual zone

Two leaving water temperature zones. In heating, the main leaving water temperature zone consists of the lowest temperature heat emitters and a mixing station to achieve the desired leaving water temperature.

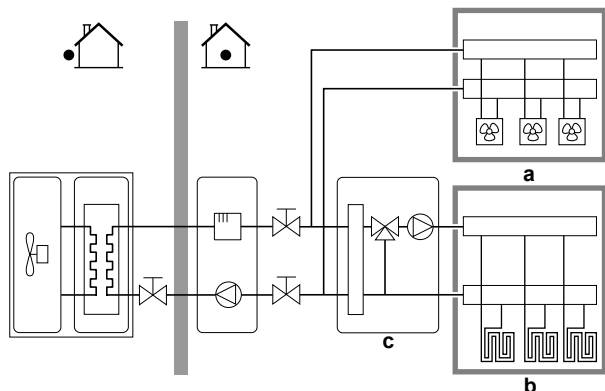

a Additional LWT zone: Highest temperature

b Main LWT zone: Lowest temperature

c Mixing station



#### INFORMATION

**Mixing station.** If your system layout contains 2 LWT zones, you can install a mixing station in front of the main LWT zone. However, other dual zone applications with shut-off valves are also possible. For more information, see the application guidelines in the installer reference guide.



#### NOTICE

NOT configuring the system in the following way can cause damage to the heat emitters. If there are 2 zones, it is important that in heating:

- the zone with the lowest water temperature is configured as the main zone, and
- the zone with the highest water temperature is configured as the additional zone.



#### NOTICE

If there are 2 zones and the emitter types are wrongly configured, water of high temperature can be sent towards a low temperature emitter (underfloor heating). To avoid this:

- Install an aquastat/thermostatic valve to avoid too high temperatures towards a low temperature emitter.
- Make sure you set the emitter types for the main zone and for the additional zone correctly in accordance with the connected emitter.

#### Bivalent

Must match your system layout. Is an external heat source (bivalent) installed?

For more information, see the application guidelines in the installer reference guide, and the settings in the configuration reference guide ([5.14] Bivalent).

ON (installed) / OFF (not installed)

#### DHW Tank<sup>(a)</sup>

Must match your system layout. DHW tank installed?

ON (installed) / OFF (not installed)

<sup>(a)</sup> Not required for floor-standing or ECH<sub>2</sub>O units.

#### DHW Tank type

Read-only.

- Integrated:  
The backup heater will also be used for domestic hot water heating.

### [10.5] System 2/4

Not applicable.

### [10.6] System 3/4

**Restriction:** This screen is only shown when the unit have a bivalent heat exchanger inside the tank.

In case an external heat source is connected to the bivalent models.

Set:

- Tank boiler (ON/OFF)
  - On
- Boiler capacity
  - Can cover heat demand: When the external heat source can cover the total heat demand.
  - Cannot cover heat demand: When the external heat source cannot cover the total heat demand.

Boiler capacity defines if the external heat source is capable of covering the total heat demand.

- Maximum capacity (select value)
  - Choose a capacity limitation that is lower than the external heat source can deliver.

Defines the maximum output if the external heat source cannot cover total heat demand.

## 7 Configuration

### [10.7] System 4/4

Set Emergency selection.

#### Emergency selection

When a heat pump failure occurs, then this setting (same as setting [5.23]) defines whether the electrical heater (backup heater / booster heater / tank boiler if applicable) can take over the space heating and DHW operation.

When there is no automatic full take-over by the electrical heater, a pop-up (with the same content as setting [5.30]) appears where you can manually acknowledge that the electrical heater can fully take over (i.e. space heating to normal setpoint and DHW operation = ON).

When the house is unattended for longer periods, we recommend to use auto SH reduced/DHW off to keep energy consumption low.

[5.23]	When heat pump failure occurs, then there is ... by the electrical heater	Full take-over
Manual	No take-over: <ul style="list-style-type: none"> <li>Space heating = OFF</li> <li>DHW operation = OFF</li> </ul>	After manual acknowledgment
Automatic	Full take-over: <ul style="list-style-type: none"> <li>Space heating to normal setpoint</li> <li>DHW operation = ON</li> </ul>	Automatic
auto SH reduced/DHW on	Partial take-over: <ul style="list-style-type: none"> <li>Space heating to reduced setpoint</li> <li>DHW operation = ON</li> </ul>	After manual acknowledgment
auto SH reduced/DHW off	Partial take-over: <ul style="list-style-type: none"> <li>Space heating to reduced setpoint</li> <li>DHW operation = OFF</li> </ul>	After manual acknowledgment
auto SH normal/DHW off	Partial take-over: <ul style="list-style-type: none"> <li>Space heating to normal setpoint</li> <li>DHW operation = OFF</li> </ul>	After manual acknowledgment



#### INFORMATION

If a heat pump failure occurs and Emergency selection is NOT set to Automatic, the following functions will remain active even if the user does NOT acknowledge emergency operation:

- Room frost protection
- Underfloor heating screed dryout
- Water pipe freeze prevention
- Disinfection

### [10.8] Backup heater

Set:

- Grid configuration:
  - Single phase
  - Three phase 3x400V+N
- Maximum capacity:
  - Slider limited depending on grid configuration and fuse. **Note:** During defrost operation, the backup heater support may go up to the maximum capacity defined here. If needed, you can limit this value (but not lower than 2 kW to ensure reliable operation).
- Fuse >10A (ON/OFF)

The maximum capacity suggested by the user interface is based on the selected grid configuration and, if applicable, the size of the fuse. An installer can however lower the maximum capacity of the backup heater using the scroll list. The table below gives an overview of the dynamic maximums of the scroll list.

Grid configuration	Fuse >10A	Maximum capacity
Single phase	(greyed out) <sup>(a)</sup>	Limited to 6 kW <sup>(b)</sup>
Three phase 3x400V+N	(greyed out) <sup>(a)(c)</sup>	Limited to 9 kW <sup>(b)</sup>

<sup>(a)</sup> The fuse setting cannot be used (i.e. installing fuses <10A is NOT allowed).

<sup>(b)</sup> But not lower than 2 kW.

<sup>(c)</sup> This functionality is NOT greyed out in early versions of the user interface software.

### [10.9] Main zone 1/4

Set:

- Emitter type
- Control

#### Emitter type

Must match your system layout. Emitter type of the main zone.

- Under floor heating
- Heat pump convector
- Radiator

The setting Emitter type influences the target delta T in heating as follows:

Emitter type Main zone	Target delta T in heating
Under floor heating	3~10°C
Heat pump convector	3~10°C
Radiator	10~20°C

Heating up or cooling down the main zone can take longer. This depends on:

- The water volume of the system
- The heater emitter type of the main zone



#### NOTICE

**Average emitter temperature** = Leaving water temperature – (Delta T)/2

This means that for a same leaving water temperature setpoint, the average emitter temperature of radiators is lower than that of underfloor heating because of a bigger delta T.

Example radiators: 40–10/2=35°C

Example underfloor heating: 40–5/2=37.5°C

To compensate, you can increase the weather-dependent curve desired temperatures.



#### INFORMATION

The maximum leaving water temperature is decided based on setting [3.12] Overheating setpoint. This limit defines the maximum leaving water **in the system**. Depending on the value of this setting, the maximum LWT setpoint will also be reduced by 5°C to allow stable control towards the setpoint.

The maximum leaving water temperature **in the main zone** is decided based on setting [1.19] Overheating water circuit, only in case [3.13.5] Bizon kit installed is enabled. This limit defines the maximum leaving water **in the main zone**. Depending on the value of this setting, the maximum LWT setpoint will also be reduced by 5°C to allow stable control towards the setpoint.

**Control**

Defines the unit control method for the main zone.

- Leaving water: Unit operation is decided based on the leaving water temperature regardless the actual room temperature and/or heating or cooling demand of the room.
- External room thermostat: Unit operation is decided by the external thermostat or equivalent (e.g. heat pump convector).
- Room thermostat: Unit operation is decided based on the ambient temperature of the dedicated Human Comfort Interface (BRC1HHDA used as room thermostat).

In case of external room thermostat control, you must also set [1.13] External room thermostat (Input source and Connection type):

Input source:

Must match your system layout. Input source of the external room thermostat for the main zone.

- Hardware
- Cloud
- Modbus

Connection type:

**Restriction:** Only applicable if [1.13] Input source = Hardware.

Must match your system layout. External room thermostat type for the main zone.

- Single contact: The used external room thermostat can only send a thermo ON/OFF condition. There is no separation between heating or cooling demand.  
Select this value in case of a connection to the heat pump convector (FWX\*).
- Dual contact: The used external room thermostat can send a separate heating/cooling thermo ON/OFF condition.  
Select this value in case of connection to multi-zoning wired controls, wired room thermostats (EKRTWA) or wireless room thermostats (EKRTTB).

**NOTICE**

If an external room thermostat is used, the external room thermostat will control the room frost protection.

**[10.10] Main zone 2/4**

Set:

- Heating setpoint mode:
  - Fixed
  - Weather dependent
- Cooling setpoint mode:
  - Fixed
  - Weather dependent

**[10.11] Main zone 3/4 (Heating WD curve)**

Defines the weather-dependent curve used to determine the leaving water temperature of the main zone in space heating operation.

**Restriction:** The curve is only used when Heating setpoint mode (main zone) = Weather dependent.

See "7.2 Weather-dependent curve" [p 32].

**[10.12] Main zone 4/4 (Cooling WD curve)**

Defines the weather-dependent curve used to determine the leaving water temperature of the main zone in space cooling operation.

**Restriction:** The curve is only used when Cooling setpoint mode (main zone) = Weather dependent.

See "7.2 Weather-dependent curve" [p 32].

**[10.13] Additional zone 1/4**

Set:

- Emitter type
- Control

**Emitter type**

Must match your system layout. Emitter type of the additional zone. For more information, see "[10.9] Main zone 1/4" [p 30].

- Under floor heating
- Heat pump convector
- Radiator

**Control**

Shows (read-only) the unit control method for the additional zone. It is determined by the unit control method for the main zone (see "[10.9] Main zone 1/4" [p 30]).

- Leaving water if the unit control method for the main zone is Leaving water.
- External room thermostat if the unit control method for the main zone is:
  - External room thermostat, or
  - Room thermostat

In case of external room thermostat control, you must also set [2.13] External room thermostat (Input source and Connection type):

Input source:

Must match your system layout. Input source of the external room thermostat for the additional zone.

- Hardware
- Cloud
- Modbus

Connection type:

**Restriction:** Only applicable if [2.13] Input source = Hardware.

Must match your system layout. External room thermostat type for the additional zone.

- Single contact: The used external room thermostat can only send a thermo ON/OFF condition. There is no separation between heating or cooling demand.  
Select this value in case of a connection to the heat pump convector (FWX\*).
- Dual contact: The used external room thermostat can send a separate heating/cooling thermo ON/OFF condition.  
Select this value in case of connection to multi-zoning wired controls, wired room thermostats (EKRTWA) or wireless room thermostats (EKRTTB).

**[10.14] Additional zone 2/4**

Set:

- Heating setpoint mode:
  - Fixed
  - Weather dependent
- Cooling setpoint mode:
  - Fixed
  - Weather dependent

**[10.15] Additional zone 3/4 (Heating WD curve)**

Defines the weather-dependent curve used to determine the leaving water temperature of the additional zone in space heating operation.

## 7 Configuration

**Restriction:** The curve is only used when Heating setpoint mode (additional zone) = Weather dependent.

See "7.2 Weather-dependent curve" ▶ 32].

### [10.16] Additional zone 4/4 (Cooling WD curve)

Defines the weather-dependent curve used to determine the leaving water temperature of the additional zone in space cooling operation.

**Restriction:** The curve is only used when Cooling setpoint mode (additional zone) = Weather dependent.

See "7.2 Weather-dependent curve" ▶ 32].

### [10.17] Configuration wizard – DHW 1/2

Set:

- Operation mode

#### Operation mode

Defines how the domestic hot water is prepared. The 3 different ways differ from each other by the way the desired tank temperature is set and how the unit acts upon it.

See the operation manual for more details.

- Reheat  
The tank can ONLY be heated by reheat operation (fixed or scheduled<sup>(a)</sup>). Use the following settings:
  - [4.11] Operation range
  - [4.24] Enable reheat schedule<sup>(a)</sup>
  - In case of fixed: [4.5] Reheat setpoint
  - In case of scheduled: [4.25] Reheat schedule<sup>(a)</sup>
  - [4.12.1] Comfort hysteresis
  - [4.19] Reheat Trigger Threshold
- Schedule and reheat  
The tank is heated according to a schedule and between the scheduled heat up cycles, reheat operation is allowed. The settings are the same as for Reheat and for Scheduled.
- Scheduled  
The tank can ONLY be heated according to a schedule. Use the following settings:
  - [4.11] Operation range
  - [4.6] Single heat-up schedule

<sup>(a)</sup> Only applicable for ECH<sub>2</sub>O units.

Related settings:

Setting	Description
[4.11] Operation range	You can set the maximum allowed tank temperature here. This is the maximum temperature that users can select for the domestic hot water. You can use this setting to limit the temperature at the hot water taps.
[4.24] Enable reheat schedule <sup>(a)</sup> (in case of Reheat)	The reheat setpoint for can be: <ul style="list-style-type: none"> <li>• Fixed (default)</li> <li>• Scheduled</li> </ul> You can switch between the two here: <ul style="list-style-type: none"> <li>• OFF = Fixed. You can now set [4.5].</li> <li>• ON = Scheduled. You can now set [4.25].</li> </ul>
[4.5] Reheat setpoint (in case of fixed reheat setpoint)	You can set the fixed reheat setpoint here. <ul style="list-style-type: none"> <li>• 20~[4.11]°C</li> </ul>

Setting	Description
[4.25] Reheat schedule <sup>(a)</sup> (in case of scheduled reheat setpoint)	You can program the reheat schedule here.
[4.12.1] Comfort hysteresis (in case of Reheat or Schedule and reheat)	You can set the reheat hysteresis here. When the tank temperature drops below the reheat temperature minus the reheat hysteresis temperature, the tank heats up to the reheat temperature. <ul style="list-style-type: none"> <li>• 1~40°C</li> </ul>
[4.19] Reheat Trigger Threshold (in case of Reheat or Schedule and reheat)	You can set the reheat trigger temperature of the domestic hot water tank to ensure sufficient energy is present in the tank here.  This setting is optimised for sufficient comfort. <ul style="list-style-type: none"> <li>• 10~85°C</li> </ul> <b>Note:</b> Always make sure to use a value lower than [4.5] Reheat setpoint.
[4.6] Single heat-up schedule (in case of Scheduled or Schedule and reheat)	You can program and activate a tank schedule here.

<sup>(a)</sup> Only applicable for ECH<sub>2</sub>O units.

### [10.18] Configuration wizard – DHW 2/2

Set:

- Tank setpoint (select value)
- Hysteresis (select value)

### [10.19] Configuration wizard

The configuration wizard is finished!

Please make sure that the commissioning check list in e-Care has been completed as well.

## 7.2 Weather-dependent curve

### 7.2.1 What is a weather-dependent curve?

#### Weather-dependent operation

The unit operates 'weather-dependent' if the desired leaving water temperature is determined automatically by the outdoor temperature. It therefore is connected to a temperature sensor on the North wall of the building. If the outdoor temperature drops or rises, the unit compensates instantly. Thus, the unit does not have to wait for feedback by the thermostat to increase or decrease the temperature of the leaving water. Because it reacts more quickly, it prevents high rises and drops of the indoor temperature and water temperature at tap points.

#### Advantage

Weather-dependent operation reduces energy consumption.

#### Weather-dependent curve

To be able to compensate for differences in temperature, the unit relies on its weather-dependent curve. This curve defines how much the temperature of the leaving water must be at different outdoor temperatures. Because the slope of the curve depends on local circumstances such as climate and the insulation of the building, the curve can be adjusted by an installer or user.

#### Type of weather-dependent curve

The type of weather-dependent curve is "2-points curve".

## Availability

The weather-dependent curve is available for:

- Main zone - Heating
- Main zone - Cooling
- Additional zone - Heating
- Additional zone - Cooling

## 7.2.2 Using weather-dependent curves

### Related screens

The following table describes:

- Where you can define the different weather-dependent curves
- When the curve is used (restriction)

To define the curve, go to...	Curve is used when...
[1.8] Main zone > Heating WD curve	[1.5] Heating setpoint mode = Weather dependent
[1.9] Main zone > Cooling WD curve	[1.7] Cooling setpoint mode = Weather dependent
[2.8] Additional zone > Heating WD curve	[2.5] Heating setpoint mode = Weather dependent
[2.9] Additional zone > Cooling WD curve	[2.7] Cooling setpoint mode = Weather dependent



### INFORMATION

#### Maximum and minimum setpoints

You cannot configure the curve with temperatures that are higher or lower than the set maximum and minimum setpoints for that zone. When the maximum or minimum setpoint is reached, the curve flattens out.

### To define a weather-dependent curve

Define the weather-dependent curve using two setpoints (b, c).

**Example:**

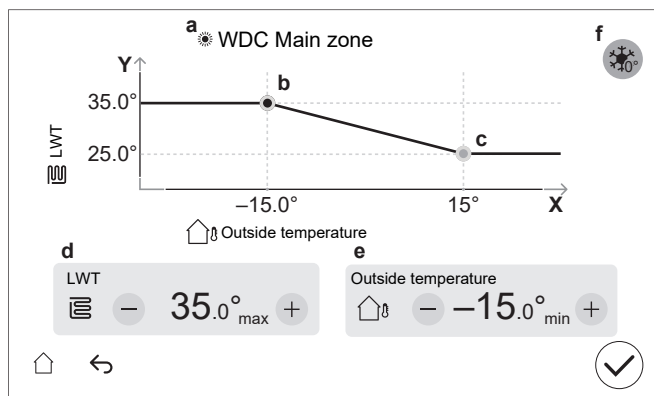

Item	Description
<b>a</b>	Selected weather-dependent curve: <ul style="list-style-type: none"> <li>• [1.8] Main zone – Heating (☀)</li> <li>• [1.9] Main zone – Cooling (❄)</li> <li>• [2.8] Additional zone – Heating (☀)</li> <li>• [2.9] Additional zone – Cooling (❄)</li> </ul>
<b>b, c</b>	Setpoint 1 and setpoint 2. You can change them: <ul style="list-style-type: none"> <li>• By dragging the setpoint.</li> <li>• By tapping the setpoint, and then using the - / + buttons in <b>d, e</b>.</li> </ul>
<b>d, e</b>	Values of the selected setpoint. You can change the values using the - / + buttons.

Item	Description
<b>f</b>	<p><b>Restriction:</b> Only shown if an increase was already selected via [1.26] for main zone, or [2.20] for additional zone.</p> <p>Increase around 0°C (same as setting [1.26] for main zone, and [2.20] for additional zone).</p> <p>Use this setting to compensate for possible heat losses of the building due to the evaporation of melted ice or snow. (e.g. in cold region countries). In heating operation, the desired leaving water temperature is locally increased around an outdoor temperature of 0°C.</p> <p><b>L:</b> Increase; <b>R:</b> Span; <b>X:</b> Outdoor temperature; <b>Y:</b> Leaving water temperature</p> <p>Possible values:</p> <ul style="list-style-type: none"> <li>• No</li> <li>• increase 2°C, span 4°C</li> <li>• increase 2°C, span 8°C</li> <li>• increase 4°C, span 4°C</li> <li>• increase 4°C, span 8°C</li> </ul>
<b>X-axis</b>	Outdoor temperature.
<b>Y-axis</b>	Leaving water temperature for the selected zone. The icon corresponds to the heat emitter for that zone: <ul style="list-style-type: none"> <li>•  Underfloor heating</li> <li>•  Heat pump convector</li> <li>•  Radiator</li> </ul>

### To fine-tune a weather-dependent curve

The following table describes how to fine-tune the weather-dependent curve of a zone:

You feel...		Fine-tune with setpoints:			
At regular outdoor temperatures ...	At cold outdoor temperatures ...	Setpoint 1 (b)		Setpoint 2 (c)	
		X	Y	X	Y
OK	Cold	↑	↑	—	—
OK	Hot	↓	↓	—	—
Cold	OK	—	—	↑	↑
Cold	Cold	↑	↑	↑	↑
Cold	Hot	↓	↓	↑	↑
Hot	OK	—	—	↓	↓
Hot	Cold	↑	↑	↓	↓
Hot	Hot	↓	↓	↓	↓

## 7.3 Menu structure: Overview installer settings



### NOTICE

When changing a setting, the operation is temporarily stopped. Operations will restart when you return to the home screen.

Depending on your unit type and the selected settings, some settings will not be visible.

### [1] Main zone

- [1.6] Setpoint range
- [1.12] Control

## 8 Commissioning

- [1.13] External room thermostat
- [1.14] Delta T heating
- [1.16] Cooling allowance
- [1.18] Delta T cooling
- [1.19] Overheating water circuit
- [1.20] Undercooling water circuit
- [1.26] Increase around 0°C
- [1.31] Daikin room thermostat

### [2] Additional zone

- [2.6] Setpoint range
- [2.12] Control
- [2.13] External room thermostat
- [2.14] Delta T heating
- [2.17] Delta T cooling
- [2.20] Increase around 0°C
- [2.33] Cooling allowance

### [3] Space heating/cooling

- [3.6] Additional zone
- [3.7] Max. heating overshoot LWT
- [3.8] Averaging time
- [3.9] Max. cooling undershoot LWT
- [3.11] Undercooling setpoint
- [3.12] Overheating setpoint
- [3.13] Bizone kit
- [3.14] Room thermostat present
- [3.15] Heatpump minimum on time

### [4] Domestic hot water

- [4.9] Clear disinfection malfunction
- [4.10] Disinfection
- [4.11] Operation range
- [4.13] DHW pump
- [4.14] Booster heater
- [4.18] Disinfection enable

### [5] Settings

- [5.1] Forced defrost
- [5.2] Quiet operation
- [5.5] Backup heater
- [5.7] Overview field settings
- [5.11] Reset fan operation hours
- [5.14] Bivalent settings
- [5.18] System restart
- [5.22] External ambient sensor offset
- [5.28] Balancing
- [5.29] Refrigerant recovery mode
- [5.32] Tank boiler present
- [5.33] Tank boiler covers heat demand
- [5.34] Maximum capacity
- [5.36] Water pipe freeze prevention
- [5.37] Bivalent present

### [7] Maintenance mode

- [7.1] Actuator test run
- [7.2] Air purge
- [7.3] Operation test run
- [7.4] UFH screed dryout
- [7.7] Operation test run settings
- [7.8] Malfunctioning

### [9] Energy

- [9.11] Boiler efficiency
- [9.12] PE factor
- [9.14] Demand response

### [10] Configuration wizard

See ["7.1 Configuration wizard"](#) [p 28].

### [11] Malfunctioning

### [13] Field IO

## 8 Commissioning



### NOTICE

**Commissioning checklists.** Make sure to complete the different commissioning checklists:

- In the installation manuals (outdoor unit and indoor unit) or in the installer reference guide
- In the Daikin e-Care app



### NOTICE

**First operation.** The first time the unit starts in heating or domestic hot water operation, the unit will shortly start up in cooling operation to guarantee the reliability of the heat pump:

- For this reason, the backup heater will increase the water temperature so that the unit does not freeze up. Depending on the water volume of the system, this can take up to a few hours. It is required to start the first time in space heating or space cooling operation (not domestic hot water operation) to limit the backup heater consumption. If you would run in domestic hot water operation for the first time, the backup heater consumption would be expected to be larger.
- Error 89-10 can occur if the unit is installed during days with large temperature variations. To reduce the risk of error 89-10 occurring, it is beneficial to wait a few hours after unlocking the unit and opening the stop valve of the outdoor unit's refrigerant vessel, and before the first start-up of the unit. If error 89-10 still occurs, the unit will shortly stop operation and then resume. The unit will continue operation, but it will take more time until the unit switches from cooling to heating.



### NOTICE

If the outdoor temperature is below 18°C, error 89-10 may occur when starting in cooling mode. Change the operating mode to heating, and repeat the process



### NOTICE

**First operation.** When the heat pump is started in operation mode cooling during first start-up of the unit, but the outdoor temperatures are below 18°C, the error 98-10 may occur.

- Change the operating mode to heating or domestic hot water and repeat the process.



### NOTICE

ALWAYS operate the unit with thermistors and/or pressure sensors/switches. If NOT, burning of the compressor might be the result.

**WARNING**

After commissioning, do NOT turn OFF the circuit breakers (c) to the units so that the protection remains activated. In case of indoor unit supplied separately (a), there are two circuit breaker. In case of indoor unit supplied from the outdoor unit (b), there is one circuit breaker.

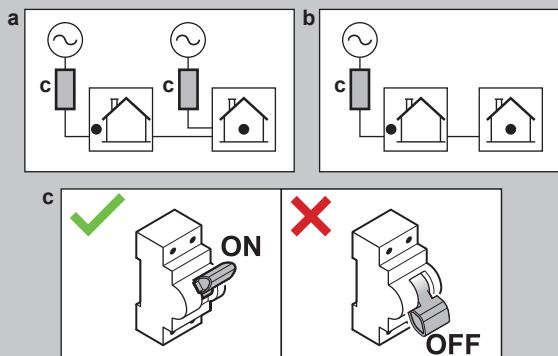
**NOTICE**

The pump is equipped with an anti-blockage safety routine. This means that the pump operates for a short period of time every 24 hours during long periods of inactivity to ensure it does not get stuck. To enable this function, the unit must be connected to the power supply all year round.

**NOTICE**

If automatic air purge valves are installed in the field piping:

- Between the outdoor unit and the indoor unit (on the entering water pipe of the indoor unit), they must be closed after commissioning.
- After the indoor unit (on the emitter side), they may remain open after commissioning.

**NOTICE**

For houses with a similar heat load as the declared heating capacity on the energy label, it is recommended to set the [5.6.2] Capacity shortage setting to 2 (Below equilibrium) and decrease the equilibrium setpoint [5.6.2] Equilibrium setpoint to the declared bivalent temperature of -10°C. (refer to product fiche in accessory bag or the online energy label database (see: <https://daikintechnicaldatahub.eu/>)).

**NOTICE**

To avoid ON/OFF behaviour of the unit it is recommended to not oversize the unit. Refer to the declared heating capacity on the energy label or the online energy label database: <https://daikintechnicaldatahub.eu/>.

**INFORMATION**

When the unit is powered ON, it will take 5 minutes for the unit to initialize. During this time the shut-off valve inlet leak stop remains closed so domestic hot water operation cannot start.

**INFORMATION**

**Protective functions – "Maintenance mode".** The software is equipped with protective functions. The unit automatically runs these functions when necessary.

**Protective functions:** [3.4] Antifrost, [5.36] Water pipe freeze prevention and [4.18] Disinfection enable.

During installation or service this behaviour is undesired. Therefore:

- At first power-on:** The maintenance mode is active, and the protective functions are disabled by default. After 12 hours, the maintenance mode will be deactivated, and the protective functions will be enabled automatically.
- Afterwards:** Whenever you go to [7] Maintenance mode the protective functions are disabled for 12 hours or until you exit Maintenance mode.

**8.1 Checklist before commissioning**

- After the installation of the unit, check the items listed below.
- Close the unit.
- Power up the unit.

<input type="checkbox"/>	You read the complete installation instructions, as described in the <b>installer reference guide</b> .
<input type="checkbox"/>	The <b>indoor unit</b> is properly mounted. <ul style="list-style-type: none"> <li>Check that all parts of the hood fitted correctly.</li> <li>Check that the locking parts are closed.</li> </ul>
<input type="checkbox"/>	The <b>outdoor unit</b> is properly mounted.
<input type="checkbox"/>	The following <b>field wiring</b> has been carried out according to this document and the applicable legislation: <ul style="list-style-type: none"> <li>Between the local supply panel and the outdoor unit</li> <li>Between indoor unit and outdoor unit</li> <li>Between the local supply panel and the indoor unit</li> <li>Between the indoor unit and the valves (if applicable)</li> <li>Between the indoor unit and the room thermostat (if applicable)</li> </ul>
<input type="checkbox"/>	The <b>normally closed shut-off valve</b> (inlet leak stop) is properly installed.
<input type="checkbox"/>	The system is properly <b>earthed</b> and the earth terminals are tightened.
<input type="checkbox"/>	The <b>fuses</b> or locally installed protection devices are installed according to this document, and have NOT been bypassed.
<input type="checkbox"/>	The <b>power supply voltage</b> matches the voltage on the identification label of the unit.
<input type="checkbox"/>	There are NO <b>loose connections</b> or damaged electrical components in the switch box.
<input type="checkbox"/>	There are NO <b>damaged components</b> or <b>squeezed pipes</b> on the inside of the indoor and outdoor units.
<input type="checkbox"/>	<b>Backup heater circuit breaker</b> F1B (field supply) is turned ON.
<input type="checkbox"/>	The correct pipe size is installed and the <b>pipes</b> are properly insulated.
<input type="checkbox"/>	There is NO <b>water leak</b> inside the indoor unit. All electric components and connections are dry.
<input type="checkbox"/>	The <b>shut-off valves</b> are properly installed and fully open.

## 8 Commissioning

<input type="checkbox"/>	If <b>automatic air purge valves</b> are installed in the field piping: <ul style="list-style-type: none"> <li>Between the outdoor unit and the indoor unit (on the entering water pipe of the indoor unit), they must be closed after commissioning.</li> <li>After the indoor unit (on the emitter side), they may remain open after commissioning.</li> </ul>
<input type="checkbox"/>	The <b>pressure relief valve</b> (space heating circuit) purges water when opened. Clean water MUST come out.
<input type="checkbox"/>	The <b>minimum water volume</b> is guaranteed in all conditions. See "To check the water volume and flow rate" in "5.1 Preparing water piping" [▶ 8].
<input type="checkbox"/>	The <b>storage tank</b> is filled completely.
<input type="checkbox"/>	The <b>domestic hot water tank</b> is filled completely.
<input type="checkbox"/>	The <b>water quality</b> complies with EU directive 2020/2184.
<input type="checkbox"/>	<b>No anti-freeze solution</b> (e.g. glycol) is added to the water.
<input type="checkbox"/>	The " <b>No glycol</b> " tag (delivered as accessory) is attached to the field piping near the filling point.
<input type="checkbox"/>	You explained to the user how to safely use the R290 heat pump. For more information about this, see the dedicated Service Manual ESIE22-02 "Systems using R290 refrigerant" (available on <a href="https://my.daikin.eu">https://my.daikin.eu</a> ).

### 8.2 Checklist during commissioning

<input type="checkbox"/>	To unlock the <b>outdoor unit</b> (compressor).
<input type="checkbox"/>	To open the <b>stop valve of the outdoor unit's refrigerant vessel</b> .
<input type="checkbox"/>	To update the <b>user interface software</b> to the latest version.
<input type="checkbox"/>	To check that the <b>minimum flow rate</b> during cooling / heating start-up / defrost / backup heater operation is guaranteed in all conditions. See "To check the water volume and flow rate" in "5.1 Preparing water piping" [▶ 8].
<input type="checkbox"/>	To perform an <b>air purge</b> .
<input type="checkbox"/>	To perform an <b>actuator test run</b> .
<input type="checkbox"/>	To perform a <b>test run</b> .
<input type="checkbox"/>	To perform (start) an <b>underfloor screed dryout</b> (if necessary).

#### 8.2.1 To unlock the outdoor unit (compressor)



##### NOTICE

During the locked state, the heat pump is NOT allowed to operate.

Limited operation / commissioning is possible via the electrical heaters linked to [5.23] Emergency selection (see " [10.7] System 4/4" [▶ 30]).

Who	Only trained installers with the required level of competences are authorised to perform the unlocking procedure (i.e. generate the Digital Key).
-----	---

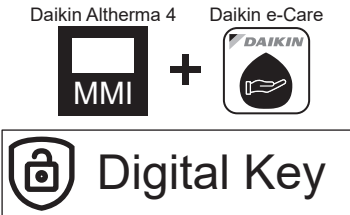
What	 <p>The compressor of Daikin Altherma 4 heat pumps is shipped in a locked state. During commissioning, it must be unlocked via the Digital Key function on the Daikin e-Care app and on the user interface of the indoor unit.</p>  <p><b>Note:</b> To clear certain R290-related errors (e.g. R290 refrigerant leakage, gas sensor errors), you also need to use the Digital Key function.</p>
When	<p><b>Option 1 (configuration wizard):</b> At first power ON of the unit the configuration wizard starts automatically. After you completed all steps in the wizard (see "7.1 Configuration wizard" [▶ 28]), the user interface will show an error message instructing to start the Digital Key function (i.e. perform the unlocking procedure).</p> <p><b>Option 2 (errors):</b> When there are errors that need the Digital Key to clear, you can start the Digital Key function from the respective error messages.</p>
Required	<ul style="list-style-type: none"> <li>Smartphone (iOS/Android supported) with the Daikin e-Care app installed.             <ul style="list-style-type: none"> <li>To download the app, see "1.1 About this document" [▶ 2].</li> <li>Offline functionality to generate the Digital Key is supported (if the user was already logged in).</li> </ul> </li> <li>Stand By Me professional account (to log in to the app), with the required level of training to handle R290 units.</li> </ul>
Attention points	<ul style="list-style-type: none"> <li>Maximum 5 unlock attempts per 15 minutes are allowed. If exceeded, the unit does NOT allow any other attempts for 1 hour.</li> <li>Once the Digital Key is entered, permissions on the unit are increased for 6 hours. It is recommended for the installer to revert to user mode when leaving the site.</li> </ul>

## Unlocking procedure (flowchart)

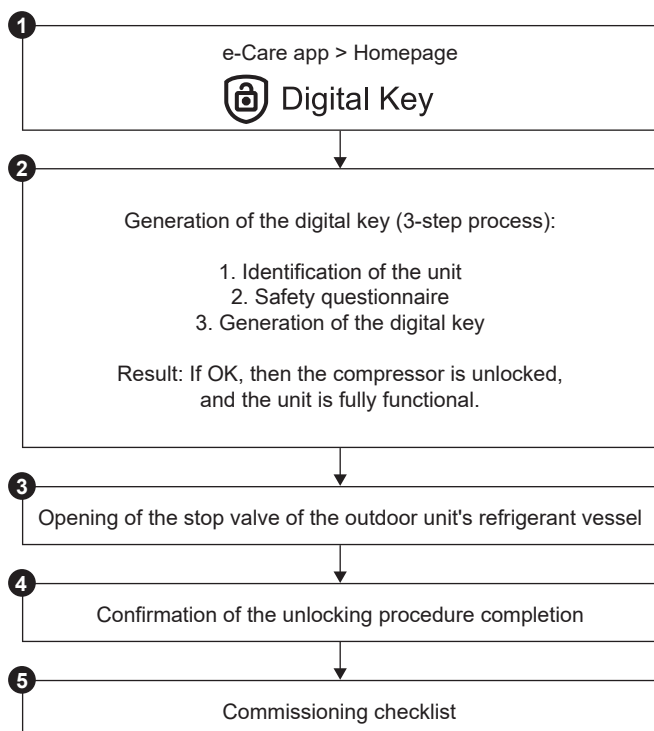

## Unlocking procedure (detailed steps)

1		<p>On the homepage of the Daikin e-Care app, go to:</p> <p><b>Result:</b> The app verifies if the installer has the required level of competences to perform the unlocking procedure. If not, an error is shown and actions are restricted.</p>
2		<p>The 3-step process to generate the Digital Key starts:</p> <ul style="list-style-type: none"> <li>2.1 Identification of the unit</li> <li>2.2 Safety questionnaire</li> <li>2.3 Generation of the Digital Key</li> </ul>
2.1	 	<p><b>Identification of the unit</b></p> <p>Scan the QR code on the name plate of the indoor unit.</p> <p>The app will check if this unit is already registered and found by Stand By Me. For new installations, you will need to register the unit before you can go to the next step.</p>

2.2	 	<p><b>Safety questionnaire</b></p> <p>Answer safety questions.</p> <p>This short list of questions helps the installer verifying that the minimum safety requirements to activate the compressor are met.</p> <p>When the checklist is completed, the app checks the answers, and generates a report. Only if all the safety requirements are met, you can go to the next step.</p>
2.3	 	<p><b>Generation of the Digital Key</b></p> <p>2.3.1 The app shows a first code. Enter this code in the user interface. For example:</p>
2.3.2	 	<p>The user interface generates a QR code. Scan this code with the app. For example:</p>
2.3.3	 	<p>The app shows a second code (= Digital Key; one-time code). Enter this code in the user interface. For example:</p>
		<p><b>Result:</b> If everything is OK, then:</p> <ul style="list-style-type: none"> <li>The user interface shows a confirmation.</li> <li>The compressor is unlocked and the unit is fully functional.</li> </ul>
3		<p>When instructed by the user interface, open the stop valve of the outdoor unit's refrigerant vessel. See "8.2.2 To open the stop valve of the outdoor unit's refrigerant vessel"  &gt; 38].</p>
4		<p>On the app, confirm the completion of the unlocking procedure.</p>
5		<p>On the app, you will be directed to the commissioning tool where you can fill in the commissioning checklist to complete the detailed checks on the installation.</p> <p>When the commissioning process is completed, the unit is ready to operate.</p>

## 8 Commissioning

### 8.2.2 To open the stop valve of the outdoor unit's refrigerant vessel



#### NOTICE

After installation, the stop valve must remain fully open to prevent damage to the seal.



#### NOTICE

When opening the stop valve of the outdoor unit's refrigerant vessel, use appropriate tools to prevent damage to the stop valve.

For safe transportation, almost all refrigerant is stored in the refrigerant vessel of the outdoor unit. During commissioning, when performing the unlocking procedure of the outdoor unit (see "8.2.1 To unlock the outdoor unit (compressor)" [p 36]), the stop valve of the refrigerant vessel must be fully opened (when instructed by the user interface) and remain fully open.

- 1 Make sure there is no gas leak on the circuit between the indoor unit and the outdoor unit by using a gas leak detector.
- 2 Remove the cap.
- 3 Turn the stop valve fully open (turn as shown until it cannot be turned any further) and leave it fully open.
- 4 Reattach the cap to prevent leakage.
- 5 Recheck to make sure there is no gas leak.

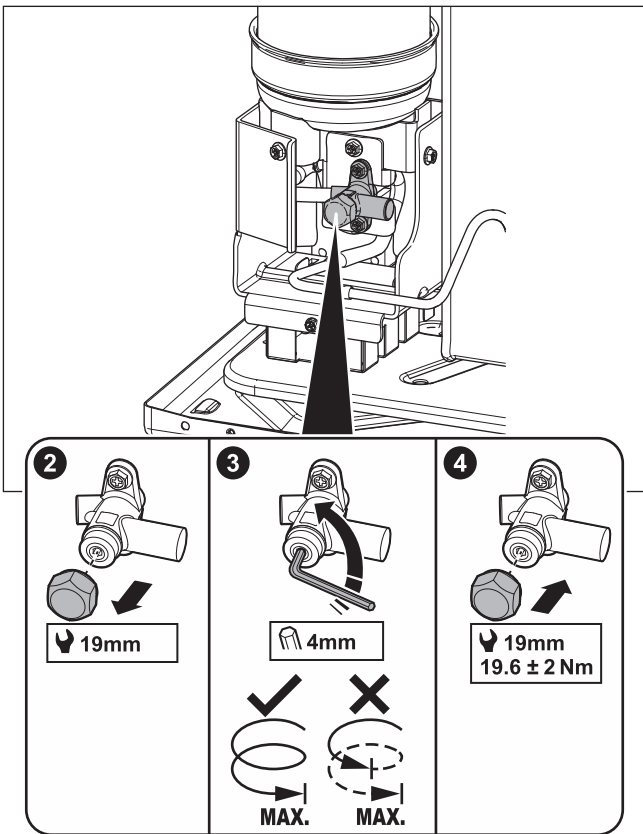

#### Sticker

The sticker on the service cover of the outdoor unit contains info about opening the stop valve of the outdoor unit's refrigerant vessel. Some text is in English. This is the translation:

#	English	Translation
8	Unlock the unit before opening the valve.	Unlock the unit before opening the valve.

#	English	Translation
8a	Unlock via the MMI and e-Care app. The MMI will instruct when to open the valve.	Unlock via the MMI (user interface of indoor unit) and e-Care app. The MMI will instruct when to open the valve.
8c	Turn fully open and leave fully open.	Turn fully open and leave fully open.

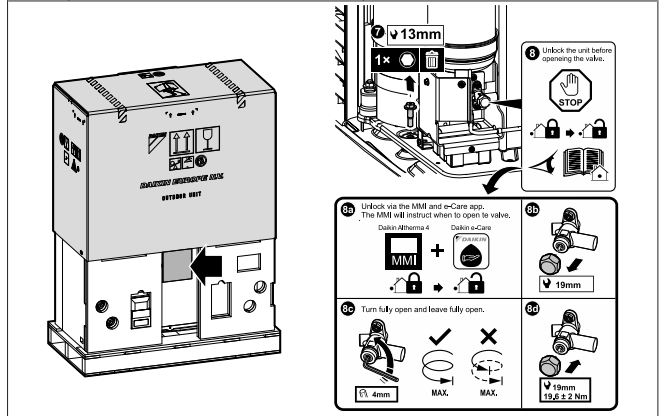

### 8.2.3 To update the user interface software

During commissioning, it is good practice to update the user interface software so that you have all latest functionality available.

- 1 Download the latest user interface software (available on <https://my.daikin.eu>; search via the Software Finder).
- 2 Put the software on a USB-stick (must be formatted as FAT32).
- 3 Power OFF the unit.
- 4 Insert the USB-stick in the USB-port located on the interface PCB (A11P).
- 5 Power ON the unit. Do NOT power ON the unit if the switch box is open.

**Result:** The software is automatically updated. You can follow its process on the user interface.

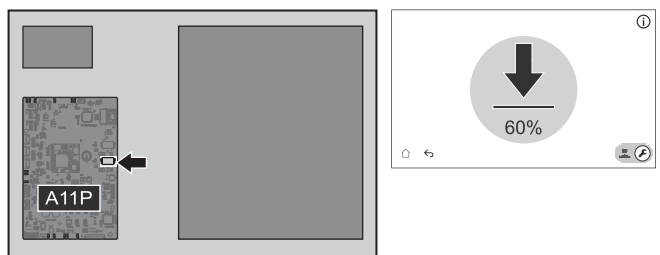

- 6 After the software is fully updated, perform a power reset again.

### 8.2.4 To check the minimum flow rate

1	Check the hydraulic configuration to find out which space heating loops can be closed by mechanical, electronic, or other valves.	—
2	Close all space heating loops that can be closed.	—
3	Start the pump test run (see "8.2.7 To perform an actuator test run" [p 40]). <ul style="list-style-type: none"> <li>▪ Choose [7.1.4] Unit pump</li> <li>▪ Choose pump speed: High</li> </ul>	—
4	Read out the flow rate <sup>(a)</sup> . If the flow rate is too low: <ul style="list-style-type: none"> <li>▪ Do air purge.</li> <li>▪ Check the function of the valve motor of M1S and M3S. Replace the valve motor if necessary.</li> </ul>	—

<sup>(a)</sup> During pump test run, the unit can operate below the minimum required flow rate.

If operation is...	Then the minimum flow rate is...
Cooling / heating start-up / defrost / backup heater operation	Required: ▪ For EPSX(B)07: 20 l/min

## 8.2.5 To perform an air purge

### NOTICE

**Second air purge.** If you need to perform an air purge a second time (after 30 minutes), you must leave the maintenance mode and then enter it again.

### NOTICE

The main and additional pump are not switched ON during an air purge. Therefore, the air purge for the mixing kit needs to be activated via normal operation.

The pumps are switched ON:

- by activating the external thermostat for the dedicated zone, which will activate the pump for that zone, or
- in the LWT control both pumps will be ON when the space heating/cooling operation is switched on on the home screen.

- Switch to installer mode.
 
- Go to [7] Maintenance mode and Confirm.
 

Maintenance mode

Entering maintenance mode can take up to ~15 minutes. The unit is finishing ongoing operations before changing over.

**Result:** Operation of Space heating/cooling and Domestic hot water will be automatically turned off.

**Remark:** If the unit is still in entering maintenance mode after 15 minutes, perform a power reset.
- Go to [7.2] Maintenance mode > Air purge.
 

7.2 - Actuator test run  
- Air purge

	Current value	Test running
Manual Space heating/cooling High		00:00:00
Flow rate	0 l/min	
Water pressure	0 bar	<b>Test started</b>
Circuit	Space heating/cooling	14 Mar 2025 16:36:54

←

- Actuator test run - Air purge

**Settings**

Settings

Manual
  Automatic

Circuit

Space heating/cooling
  Tank

Pump speed

Off
  Low speed
 High speed

←

Settings	
▪ Manual	▪ Automatic
Circuit:	
▪ Space heating/cooling	▪ Tank
Pump speed:	
▪ Off	▪ Low speed
	▪ High speed
- Tap Start to run the air purge.  
**Result:** The air purge starts. It stops automatically after some time.
- Tap Stop to stop the air purge.  
**Result:** The air purge stops.
- After the air purge test:
  - Choose ← to go back in the menu.
  - Choose ⬆ to leave the Maintenance mode.
- When leaving Maintenance mode, the user interface automatically restores operation (Space heating/cooling and Domestic hot water) as it was before entered Maintenance mode. Check if all operation modes are activated as expected.

## 8.2.6 To perform an operation test run

### NOTICE

Before starting an operation test run make sure the minimum flow requirements are guaranteed (See "8.2.4 To check the minimum flow rate" ▶ 38).

- Switch to installer mode.
 
- Go to [7] Maintenance mode and Confirm.
 

Maintenance mode

Entering maintenance mode can take up to ~15 minutes. The unit is finishing ongoing operations before changing over.

**Result:** Operation of Space heating/cooling and Domestic hot water will be automatically turned off.

**Remark:** If the unit is still in entering maintenance mode after 15 minutes, perform a power reset.

## 8 Commissioning

3	Go to [7.7] Maintenance mode > Operation test run settings, and define the target temperatures that you want to use during the operation test run.	
⚙️[030]	[7.7.1] Space heating delta T target	Delta T target that will be used during the space heating test run. 2~20°C
⚙️[031]	[7.7.2] Space heating leaving water target	Target leaving water temperature that will be used during the space heating test run. 5~71°C
⚙️[032]	[7.7.3] Space heating room	Target room temperature that will be used during the space heating test run. 5~30°C
⚙️[033]	[7.7.4] Space cooling delta T target	Delta T target that will be used during the space cooling test run. 2~10°C
⚙️[034]	[7.7.5] Space cooling leaving water target	Target leaving water temperature that will be used during the space cooling test run. 5~30°C
⚙️[035]	[7.7.6] Space cooling room	Target room temperature that will be used during the space cooling test run. 5~30°C
⚙️[077]	[7.7.7] Tank setpoint <sup>(a)</sup>	Target tank temperature that will be used during the tank heat-up test run. 20~85°C
⚙️[145]	[7.7.9] Tank target BSH test run <sup>(b)</sup>	Target tank temperature that will be used during the booster heater test run. 25~60°C
4	Go to [7.3] Maintenance mode > Operation test run	
5	Select an operation to test. <b>Example:</b> [7.3.1] Space heating.	
5.1	Tap Start to run the operation test. <b>Result:</b> The operation test starts.	
5.2	Tap Stop to stop the operation test. <b>Note:</b> Even if the test run has been stopped, it can continue up to its minimum operation time set in [3.15] Heatpump minimum on time.	
6	After the operation test run:	
6.1	Choose ↶ to go back in the menu.	
6.2	Choose 🏠 to leave the Maintenance mode.	

7	When leaving Maintenance mode, the user interface automatically restores operation (Space heating/cooling and Domestic hot water) as it was before entered Maintenance mode. Check if all operation modes are activated as expected.
---	--

<sup>(a)</sup> If a tank is not connected, this setting will still appear for wall-mounted units but it will NOT be effective.



<sup>(b)</sup> If a tank is not connected, this setting will NOT appear for wall-mounted units.

### 8.2.7 To perform an actuator test run

#### Purpose

Perform an actuator test run to confirm the operation of the different actuators. For example, when you select Unit pump, a test run of the pump will start.

1	Switch to installer mode.
2	Go to [7] Maintenance mode and Confirm.
	<b>Result:</b> Operation of Space heating/cooling and Domestic hot water will be automatically turned off.
	<b>Remark:</b> If the unit is still in entering maintenance mode after 15 minutes, perform a power reset.
3	Go to [7.1] Maintenance mode > Actuator test run.
4	Select an actuator to test. <b>Example:</b> [7.1.4] Unit pump
4.1	 Settings: For certain actuators, you can define some settings before the test.
4.2	Tap Start to run the test. <b>Result:</b> <ul style="list-style-type: none"> <li>Values for actuator shown in the detail section.</li> <li>Time measurement starts.</li> </ul>
4.3	Tap Stop to stop the test. <b>Note:</b> Due to a required after run time, the test run can continue for a certain time even when it has been stopped.
5	After the actuator test:

5.1	Choose  to go back in the menu.
5.2	Choose  to leave the Maintenance mode.
6	When leaving Maintenance mode, the user interface automatically restores operation (Space heating/cooling and Domestic hot water) as it was before entered Maintenance mode. Check if all operation modes are activated as expected.

### Possible actuator test runs

Depending on your unit type and selected settings, some tests will not be visible.



#### INFORMATION\*

During the actuator tests for Booster heater, Bivalent and Tank boiler the setpoint is not respected. The component will be stopped when reaching its internal limits. If these limits are reached the actuator test will continue and activate that component again when the limitations allow its operation.

- [7.1.1] Booster heater test
- [7.1.2] Bivalent test
- [7.1.3] Tank boiler test
- [7.1.4] Unit pump test



#### INFORMATION

Make sure that all air is purged before executing the test run. Also avoid disturbances in the water circuit during the test run.

- [7.1.5] Diverter valve test (3-way valve for switching between space heating and tank heating)
- [7.1.6] Backup heater test
- [7.1.7] Tank valve test
- [7.1.8] Bypass valve test

### Bizone mixing kit actuator tests



#### INFORMATION

This functionality is NOT available in early versions of the user interface software.

- [7.1.9] Bizone kit mixing valve test
- [7.1.10] Bizone kit direct pump test
- [7.1.11] Bizone kit mixed pump test

To execute an actuator test on the Bizone mixing kit go to home screen and turn on operation of Space heating/cooling and adapt the setpoint of the main zone. Then visual check if the pumps are working and the mixing valve are turning.

### 8.2.8 To perform an underfloor heating screed dryout



#### NOTICE

The installer is responsible for:

- contacting the screed manufacturer for the maximum allowed water temperature, to avoid cracking the screed,
- programming the underfloor heating screed dryout schedule according to the initial heating instructions of the screed manufacturer,
- checking the proper functioning of the setup on a regular basis,
- performing the correct program complying with the type of the used screed.



#### NOTICE

Before starting an underfloor heating screed dryout make sure the minimum flow requirements are guaranteed (See "8.2.4 To check the minimum flow rate" [p 38]).



#### NOTICE

When two zones are selected the underfloor heating screed dryout can only be executed on the main zone.





#### NOTICE



When there is a power failure, the underfloor heating screed dryout will continue where it was interrupted in the underfloor heating screed dryout program.



#### INFORMATION

The procedure below indicates that you need to tap Stop to stop the function, but the Stop button is NOT available in early versions of the user interface software. Instead, use  or  to stop the function.

- 1 Switch to installer mode.
 

  5678
- 2 Go to [7] Maintenance mode and Confirm .
 

Maintenance mode



Entering maintenance mode can take up to ~15 minutes. The unit is finishing ongoing operations before changing over.

Cancel
Confirm

**Result:** Operation of Space heating/cooling and Domestic hot water will be automatically turned off.

**Remark:** If the unit is still in entering maintenance mode after 15 minutes, perform a power reset.
- 3 Go to [7.4] Maintenance mode > UFH screed dryout
 

7.4 -  UFH screed dryout

 Details
 Program
▶ Start

 All zones



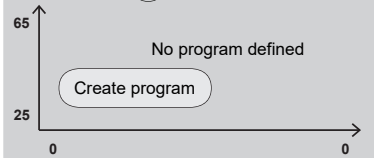

No program defined

Create program



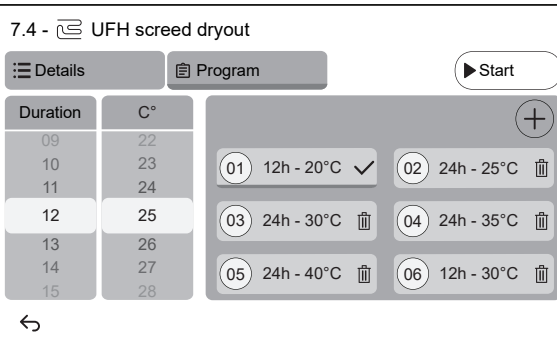

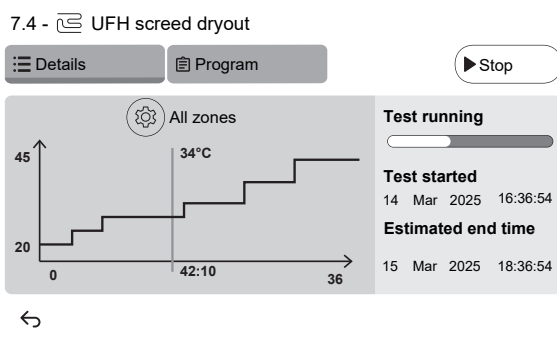
## 9 Hand-over to the user

3.1	<p>Tap on Create program or tap on Program and  to define a program step. A program can consists of multiple program-steps and a maximum of 30 program-steps.</p>  <p>Each program step contains the sequence number, the duration and desired leaving water temperature.</p>
3.2	<p> Settings:</p> <p><b>Note:</b> This functionality is NOT available in early versions of the user interface software. Underfloor heating screed dryout can only be executed on the main zone.</p>
3.3	<p>Tap Start to run the underfloor heating screed dryout.</p>  <p><b>Result:</b></p> <ul style="list-style-type: none"> <li>▪ The underfloor heating screed dryout starts. It stops automatically when all steps are done.</li> <li>▪ A progress bar indicates where the program is currently situated.</li> <li>▪ The program start time and estimated end time based on the current time and duration of the program are displayed</li> <li>▪ The underfloor heating screen is used as home screen until the finish of the program.</li> </ul>
3.4	Tap Stop to stop the underfloor heating screed dryout.
4	After the underfloor heating screed dryout:
4.1	Choose  to go back in the menu.
4.2	Choose  to leave the Maintenance mode
5	When leaving Maintenance mode, the user interface automatically restores operation (Space heating/cooling and Domestic hot water) as it was before entered Maintenance mode. Check if all operation modes are activated as expected.

- Make sure that the user has the printed documentation and ask him/her to keep it for future reference. Inform the user that he/she can find the complete documentation at the URL mentioned earlier in this manual.
- Explain to the user how to properly operate the system and what to do in case of problems.
- Show the user what to do for the maintenance of the unit.
- Explain about energy saving tips to the user as described in the operation manual.
- Explain to the user to NOT turn OFF the circuit breakers (c) to the units so that the protection remains activated. In case of indoor unit supplied separately (a), there are two circuit breaker. In case of indoor unit supplied from the outdoor unit (b), there is one circuit breaker.

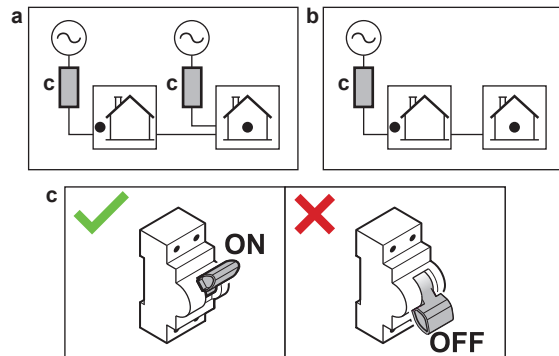

- Explain to the user that when they want to dispose of the unit, that they cannot do it themselves, but that they need to contact a Daikin certified technician.
- Explain to the user how to safely use the R290 heat pump. For more information about this, see the dedicated Service Manual ESIE22-02 "Systems using R290 refrigerant" (available on <https://my.daikin.eu>).

## 9 Hand-over to the user

Once the test run is finished and the unit operates properly, make sure the following is clear for the user:

- Fill in the installer setting table (in the operation manual) with the actual settings.

## 10 Technical data

A **subset** of the latest technical data is available on the regional Daikin website (publicly accessible). The **full set** of the latest technical data is available on the Daikin Business Portal (authentication required).

### 10.1 Piping diagram: Indoor unit

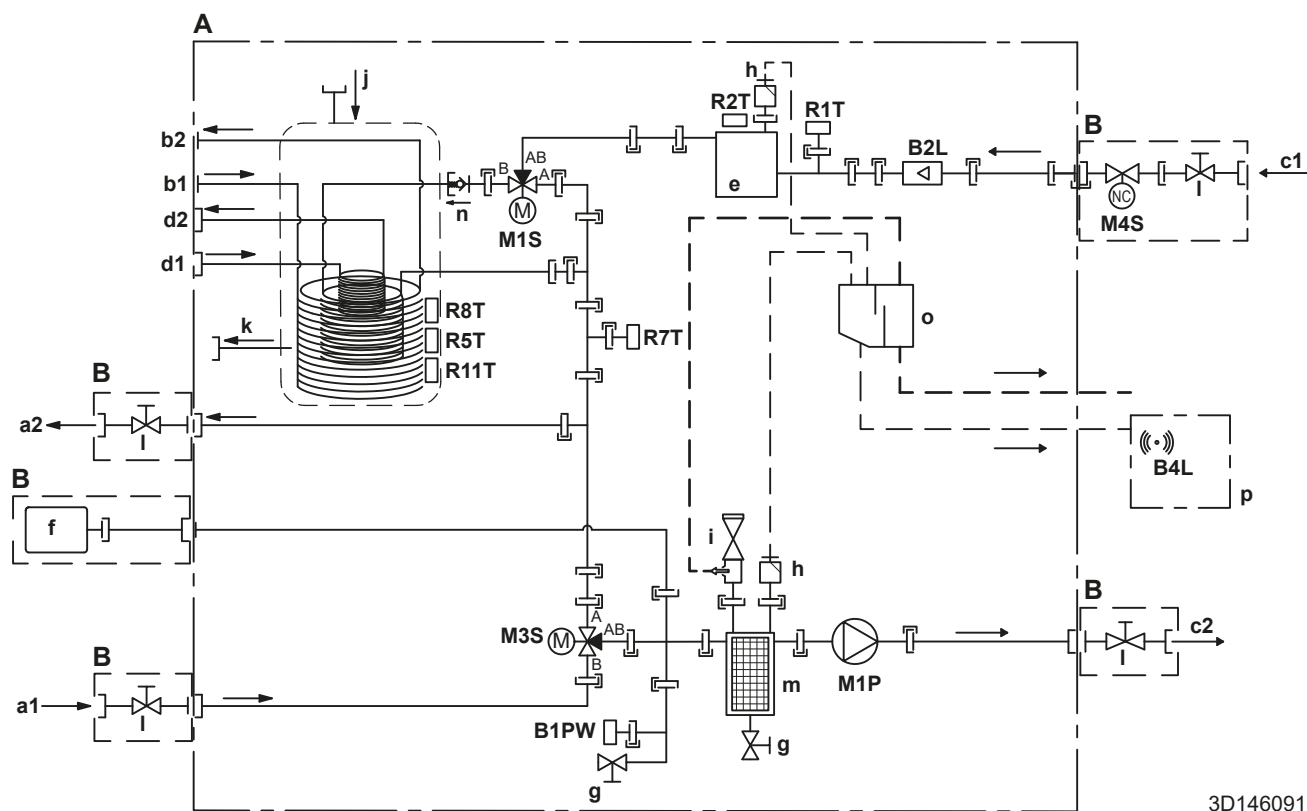

3D146091 A

A	Indoor unit
B	Field installed
C	Optional
a1	Space heating/cooling – Water IN (female, 1")
a2	Space heating/cooling – Water OUT (female, 1")
b1	DHW – Cold water IN (male, 1")
b2	DHW – Hot water OUT (male, 1")
c1	Water IN from outdoor unit (female, 1")
c2	Water OUT to outdoor unit (female, 1")
d1	Water IN from bivalent heat source (screw connection, female, 1")
d2	Water OUT to bivalent heat source (screw connection, female, 1")
e	Backup heater
f	Expansion vessel
g	Drain valve
h	Automatic air purge valve
i	Safety valve (male 1" – female 1")
j	Drainback solar - Water IN
k	Drainback solar - Water OUT
l	Shut-off valve (male 1" – female 1")
m	Magnetic filter / dirt separator
n	Check valve
o	Separator box
p	Gas sensor box

Sensors and actuators:	
B1PW	Space heating water pressure sensor
B2L	Flow sensor
B4L	Gas sensor
M1P	Pump
M1S	DHW tank valve (3-way valve)
M3S	Bypass valve (3-way valve)
M4S	Normally closed shut-off valve (inlet leak stop)(quick coupling – female 1")
Thermistors:	
R1T	Thermistor (water IN)
R2T	Thermistor (backup heater – water OUT)
R5T, R8T, R11T	Thermistor (tank)
R7T	Thermistor (tank - water OUT)
Connections:	
— —	Screw connection
—>>	Flare connection
— —	Quick coupling
—●—	Brazed connection

## 10 Technical data

### 10.2 Wiring diagram: Indoor unit

See the internal wiring diagram supplied with the unit (on the inside of the indoor unit switch box cover). The abbreviations used are listed below. There are checkboxes for each Field IO connection on the internal wiring diagram. It is recommended to mark the checkbox for the selected standard option after wiring.

#### Checkboxes internal wiring diagram: Example

This example shows how to mark a checkbox on the internal wiring diagram.

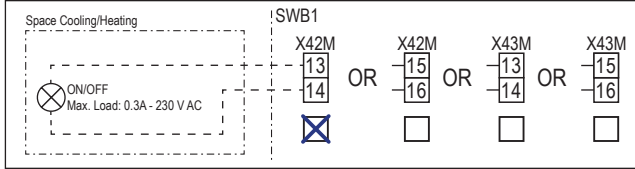

#### Notes to go through before starting the unit

English	Translation
Notes to go through before starting the unit	Notes to go through before starting the unit
X2M	Main terminal – Outdoor unit
X40M	Main terminal – Indoor unit
X41M	Main terminal – Backup heater
X42M, X43M	Field wiring for high voltage
X44M, X45M	Field wiring for SELV (Safety Extra Low Voltage)
-----	Earth wiring
-----	Field supply
①	Several wiring possibilities
	Option
	Not mounted in switch box
	Wiring depending on model
	PCB
Note 1: Connection point of the power supply for the BUH should be foreseen outside the unit.	Note 1: Connection point of the power supply for the backup heater should be foreseen outside the unit.
<b>Backup heater power supply</b>	<b>Backup heater power supply</b>
<input type="checkbox"/> 6 kW (1N~, 230 V)	<input type="checkbox"/> 6 kW (1N~, 230 V)
<input type="checkbox"/> 9 kW (3N~, 400 V)	<input type="checkbox"/> 9 kW (3N~, 400 V)
<b>User installed options</b>	<b>User installed options</b>
<input type="checkbox"/> Remote user interface	<input type="checkbox"/> Dedicated Human Comfort Interface (BRC1HHDA used as room thermostat)
<input type="checkbox"/> Ext. indoor thermistor	<input type="checkbox"/> External indoor thermistor
<input type="checkbox"/> Ext outdoor thermistor	<input type="checkbox"/> External outdoor thermistor
<input type="checkbox"/> Safety thermostat	<input type="checkbox"/> Safety thermostat
<input type="checkbox"/> Smart Grid	<input type="checkbox"/> Smart Grid
<input type="checkbox"/> WLAN cartridge	<input type="checkbox"/> WLAN cartridge
<input type="checkbox"/> Bizone mixing kit	<input type="checkbox"/> Bizone mixing kit
<b>Main LWT</b>	<b>Main leaving water temperature</b>
<input type="checkbox"/> On/OFF thermostat (wired)	<input type="checkbox"/> ON/OFF thermostat (wired)
<input type="checkbox"/> On/OFF thermostat (wireless)	<input type="checkbox"/> ON/OFF thermostat (wireless)
<input type="checkbox"/> Ext. thermistor	<input type="checkbox"/> External thermistor
<input type="checkbox"/> Heat pump convector	<input type="checkbox"/> Heat pump convector
<b>Add LWT</b>	<b>Additional leaving water temperature</b>
<input type="checkbox"/> On/OFF thermostat (wired)	<input type="checkbox"/> ON/OFF thermostat (wired)
<input type="checkbox"/> On/OFF thermostat (wireless)	<input type="checkbox"/> ON/OFF thermostat (wireless)
<input type="checkbox"/> Ext. thermistor	<input type="checkbox"/> External thermistor

English	Translation
<input type="checkbox"/> Heat pump convector	<input type="checkbox"/> Heat pump convector

#### Position in switch box

English	Translation
Position in switch box	Position in switch box

#### Legend

A1P		Hydro PCB
A2P	*	ON/OFF thermostat (PC=power circuit)
A3P	*	Heat pump convector
A6P		Multistep backup heater PCB
A12P		User interface PCB
A14P	*	PCB of the dedicated Human Comfort Interface (BRC1HHDA used as room thermostat)
A15P	*	Receiver PCB (wireless ON/OFF thermostat)
A30P	*	Bizone mixing kit PCB
F1B	#	Overcurrent fuse - Backup heater
F2B	#	Overcurrent fuse - Main
K1A, K2A	*	High voltage Smart Grid relay
M2P	#	Domestic hot water pump
M2S	#	2-way valve for cooling mode
M4S		Normally closed shut-off valve (inlet leak stop)
P* (A14P)	*	Terminal
PC (A15P)	*	Power circuit
Q*DI	#	Earth leakage circuit breaker
Q1L		Thermal protector backup heater
Q4L	#	Safety thermostat
R1H (A2P)	*	Humidity sensor
R1T (A2P)	*	Ambient sensor ON/OFF thermostat
R1T (A14P)	*	Ambient sensor user interface
R1T (A15P)	*	Ambient sensor user interface
R2T (A2P)	*	External sensor (floor or ambient)
R6T	*	External indoor or outdoor ambient thermistor
S1S	#	Preferential kWh rate power supply contact
S2S	#	Electricity meter pulse input 1
S3S	#	Electricity meter pulse input 2
S4S	#	Smart Grid feed-in (Smart Grid photovoltaic power pulse meter)
S10S-S11S	#	Low voltage Smart Grid contact
S12S	#	Gas meter input
S13S	#	Solar input
ST6 (A30P)	*	Connector
X*A, X*Y, X*Y*		Connector
X*M		Terminal strip
Z*C		Noise Filter (Ferrite core)

\* Optional  
# Field supply

## Translation of text on wiring diagram

English	Translation
(1) Main power connection	(1) Main power connection
Indoor unit supplied separately	Indoor unit supplied separately (Standard)
Indoor unit supplied from outdoor unit	Indoor unit supplied from outdoor unit
Normal kWh rate power supply	Normal kWh rate power supply
Outdoor unit	Outdoor unit
Standard	Standard
SWB	Switch box
(2) Backup heater power supply	(2) Backup heater power supply
4-pole fuse	4-pole fuse
(3) User interface	(3) User interface
Remote user interface	Dedicated Human Comfort Interface (BRC1HHDA used as room thermostat)
Voltage	Voltage
OR	OR
SD card	Card slot for WLAN cartridge
3rd generation WLAN cartridge	Third generation WLAN cartridge
(4) Shut-off valve - Inlet leak stop	(4) Normally closed shut-off valve (inlet leak stop)
(5) Ext. thermistor	(5) External thermistor
External ambient sensor option (indoor or outdoor)	External ambient sensor option (indoor or outdoor)
Voltage	Voltage
(6) Field supplied options	(6) Field supplied options
12 V DC pulse detection (voltage supplied by PCB)	12 V DC pulse detection (voltage supplied by PCB)
16 V DC detection (voltage supplied by PCB)	16 V DC detection (voltage supplied by PCB)
230 V AC Control Device	230 V AC Control Device
Alarm output	Alarm output
Bizone mixing kit	Bizone mixing kit
Contact rating	Contact rating
Continuous	Continuous current
DHW pump output	Domestic hot water pump output
DHW pump	Domestic hot water pump
Electric pulse meter input	Electricity meter
Ext. heat source	External heat source
For HV Smart Grid	For high voltage Smart Grid
For LV Smart Grid	For low voltage Smart Grid
Gas meter	Gas meter
Inrush	Inrush current
Max. load	Maximum load
Min. load	Minimum load
ON/OFF output	ON/OFF output
Only for HPSU	Only for HPSU
Only for HPSU solar input	Only for HPSU solar input
Preferential kWh rate power supply contact	Preferential kWh rate power supply contact
Safety thermostat contact	Safety thermostat contact
Shut-off valve NC	Shut-off valve – Normally closed
Shut-off valve NO	Shut-off valve – Normally open
Smart Grid PV power pulse meter	Smart Grid photovoltaic power pulse meter
Space cooling/heating	Space cooling/heating

English	Translation
Voltage	Voltage
(7) External On/OFF thermostats and heat pump convector	(7) External ON/OFF thermostats and heat pump convector
Additional LWT zone	Additional leaving water temperature zone
For external sensor (floor or ambient)	For external sensor (floor or ambient)
For heat pump convector	For heat pump convector
For wired On/OFF thermostat	For wired ON/OFF thermostat
For wireless On/OFF thermostat	For wireless ON/OFF thermostat
Main LWT zone	Main leaving water temperature zone
Max. load	Maximum load

# 10 Technical data

## Electrical connection diagram

For more details, please check the unit wiring.

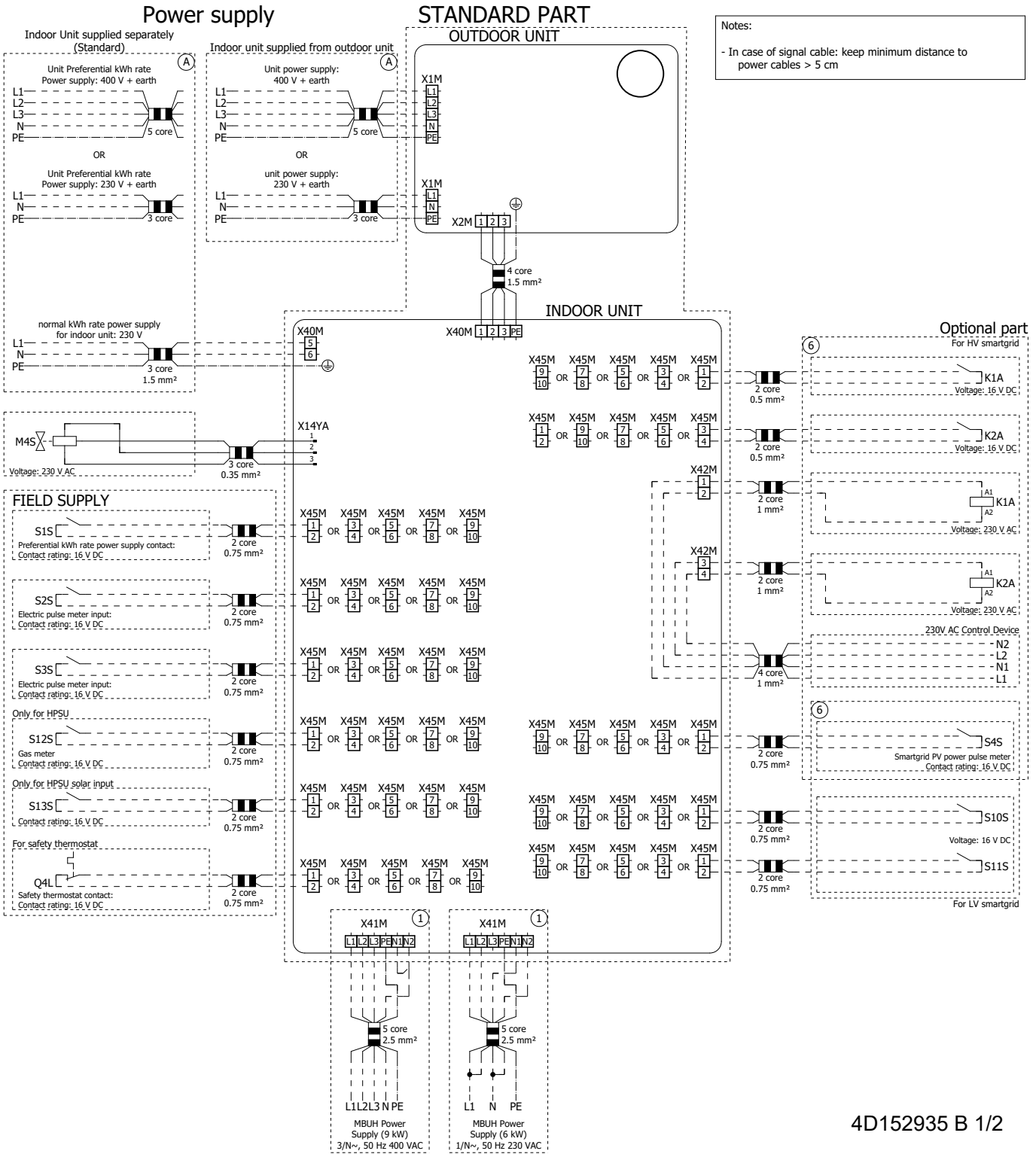

Optional part

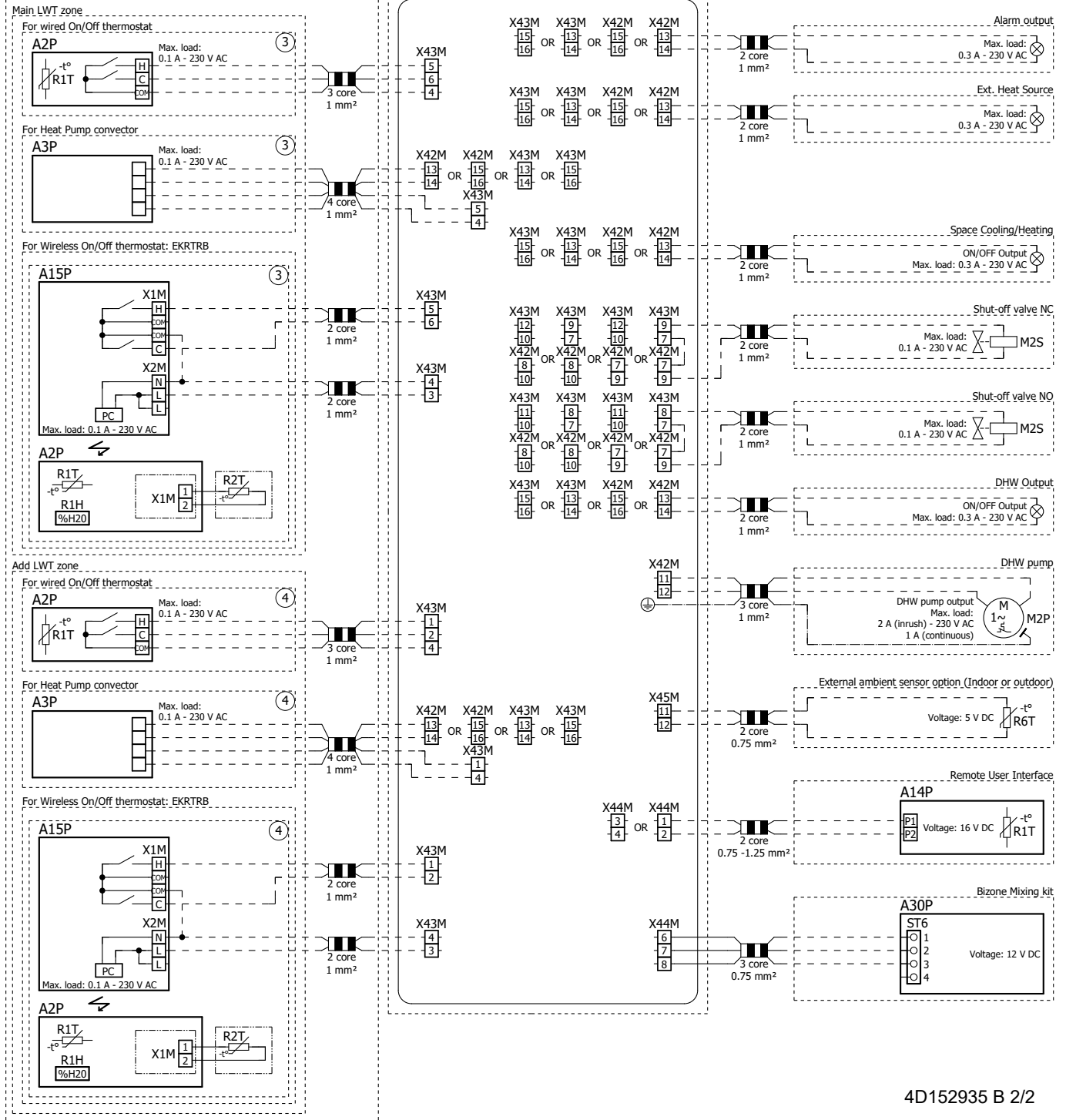

4D152935 B 2/2



4P820807-1 0000000N

Copyright 2025 Daikin

**DAIKIN EUROPE N.V.**

Zandvoordestraat 300, B-8400 Oostende, Belgium

4P820807-1 2025.09